



LYNX POWER 3 OUTDOOR HARSH

SPECIFICATIONS

- The Lynx Power 3 (LP3) Outdoor Harsh maintains efficient AC Emergency Power to operate all elevators, providing superior dependability and security to commercial/industrial environments in a small footprint.

POWER RATING

- 5 kVA - 80 kVA output uses the latest DSP/PWM technology to provide the most advanced performance and reliability features.

PROTECTION

- Provides overload, surge and undercurrent protection using DSP/PWM technology and DSPM Watchdog Software to protect system performance and reliability.
- Surge protection against load surges as defined in ANSI/IEEE C62.45 category A and B.

INPUT

- 208, 240, 480 VAC input 60Hz

OUTPUT

- 208, 240, 480 is $\geq 92\%$ efficient at 100% linear load

BATTERIES

- 10 Minutes Standard (Consult Factory for 90 minutes or greater).
- Sealed, maintenance-free, lead calcium (AGM) batteries.
- 10-Year prorated warranty.
- DSP/PWM Smart Battery Monitoring System is TEMPERATURE COMPENSATED maintaining maximum runtime and battery life.
- Microprocessor controlled recharge and DSP/PWM overcharge protection standard.

CODES

- UL 924, UL 1778, meets NFPA 101, NFPA 70, NEC and OSHA standards
- Cities of Chicago, Los Angeles and New York approved
- Complies with the Buy American Act



30 kVA - 150 kVA

Three Phase

Uninterrupted

Emergency

Lighting and

Power

Systems

REGEN POWER

- Lynx Power 3 Outdoor Harsh is designed to convert regenerated power from the elevator to recharge the battery during a power outage. Lynx Power operates in stand-by mode when utility power is available allowing the regenerative elevated power to be absorbed into the building emulating normal utility operating conditions.

DIAGNOSTICS AND MAINTENANCE

- DSP/PWM technology and DSPM Watchdog Software provides complete self diagnostic capabilities and LED Monitoring.
- Informative advanced Display and Alarms keep you in control of your emergency lighting environment 24/7.
- Automatically performs periodic self-tests ensuring a safely lighted environment prior to an emergency.
- Single point of testing instead of multiple testing points with battery packs.

NEMA 3R CABINET

- Modular design enables flexible installation
- Forced air cooling for maximum reliability
- All systems are self contained and require external battery cabinet(s)

INSTALLATION

- Modular design and small footprint allow easy installation in electrical closet or other convenient locations
- Phone assisted factory start-up standard for all systems
- Extended warranty available

SPECIAL APPLICATIONS

- DSPM offers numerous optional devices to meet unusual or difficult application parameters.
- ECM - Environmental Circuit Module allows fixtures and lamps on the emergency circuit(s) to be operated by normal switching and/or dimming devices in NON-emergency conditions.

WARRANTY

- 1-Year full warranty on system electronics
- System 1-year on-site warranty labor with DSPM phone assisted start-up
- 5-Year powertrain warranty
- Maintenance contracts available
- Battery warranty 1-year with 9-years pro-rated

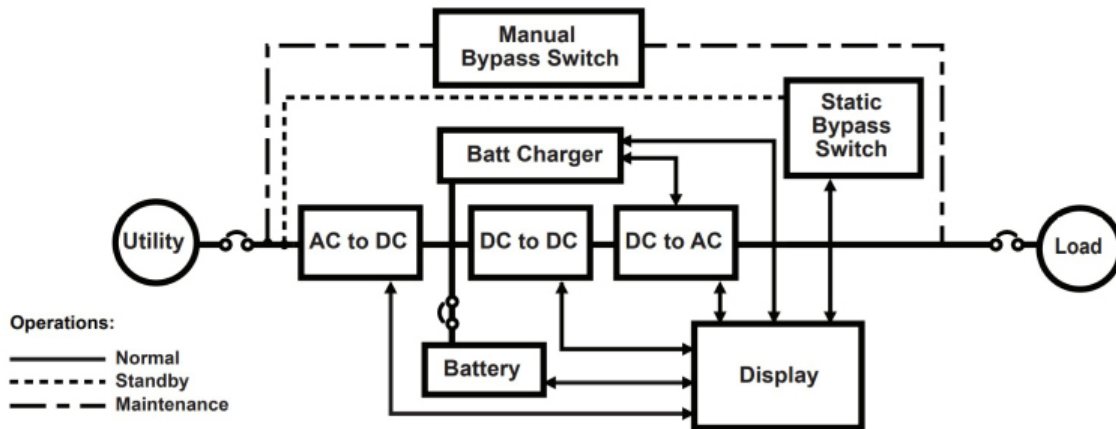

Elevator Motor Sizes(HP)	LP3 Power (KVA)	Inverter Cabinet			Battery Cabinet				Battery Type	Voltage (VAC)		Input/Output Protection	Battery Type
		W	H	D	Number of Cabinets	W	H	D		Input	Output		
HP	KVA								Sealed lead Acid (SLA)	208VAC 480VAC 208Y/120 VAC 480Y/120 VAC	208Y/120 VAC 480Y/120 VAC	circuit breakers standard	UL924 UL1778 NFPA101 NFPA70 (NEC)
15	30	46	76	36	N/A								
20	40	46	76	36	N/A								
25	50	46	76	36	1	46	76	36					
30	60	46	76	36	1	46	76	36					
40	80	46	76	36	1	46	76	36					
50	100	46	76	36	2	46	76	36					
60	120	46	76	36	2	46	76	36					
75	150	46	76	36	3	46	76	36					

The Lynx Power 3 Outdoor Harsh provides the simplicity and reliability that is critical when providing an alternative source of power to any environment. Easy installation ...”simplicity”...connect the LP3 Outdoor Harsh to the emergency circuit(s) and everything is backed up...”reliability”...during a power outage. LP3 Outdoor Harsh will simply continue to operate at “full elevation operation.” DSPM Watchdog© software keeps your environment safe while self-diagnostics help maintain equipment to a high standard. Superior surge suppression assures the highest quality of power being delivered to all loads all time. Equipment, elevator, and lamp life are maximized.

We sincerely hope you never experience a real emergency, but if you do, you deserve the **security, safety** and **peace of mind** that the Lynx Power 3 Outdoor Harsh **DSPM** ensures.

ORDERING INFORMATION

To obtain the appropriate model number for your system, we kindly request that you follow the five steps outlined below:

1. Determine your elevator motor size, measured in horsepower (HP). The available options are 15, 20, 25, 30, 40, 50, 60, 70, 80, 90, and 100 HP.
2. Determine your emergency lighting load, measured in either kilovolt-amperes (KVA) or kilowatts (KW). The available options are 1, 10, 15, 20, 25, 30, 35, 40, 45, 50, 55, 60, 65, 70, 75, 80, 85, 90, 95, and 100 KVA/KW.
3. Identify your input voltage. The available options are 208, 208Y120, 480, and 480Y277.
4. Identify your output voltage. The available options are 208Y120 and 480Y277.
5. Specify the backup run time that you require, measured in minutes. The available options are 5, 10, 20, 30, 40, 50, 60, 90, and 120 minutes.

Once you have completed these five steps, please send your response via email to sales@dspmanufacturing.com to receive a quote. Please note that if you require a custom specification, our sales team would be happy to assist you, and you can contact them at the same email address.

NOTES:

1-Consult factory for other voltage requirements. Special voltages may effect the weight, size and number of cabinets.

2-One ECM is used per switching device or circuit.

3-Consult factory for other run times.

*EMB cannot be used with OCB.

Specifications subject to change without notice.

MECHANICAL FOOTPRINT

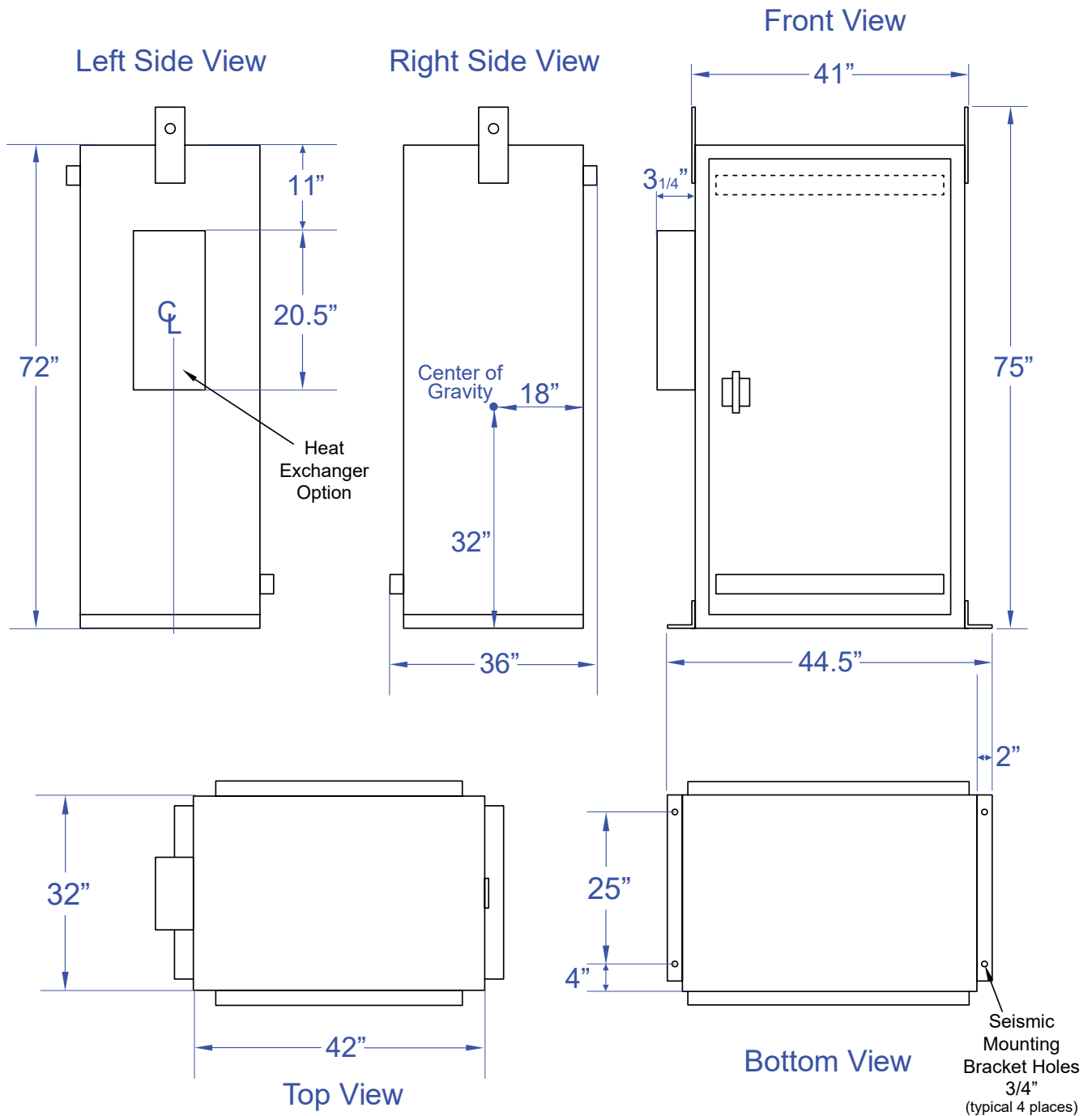

Per code requirements please leave 3" on each side of the cabinet including the back, and a 3 foot clearance in front.

Notice: This drawing contains confidential and proprietary data originated. All design, manufacturing, reproduction, use and sale rights are expressly reserved. The recipient agrees by accepting this document, not to supply or disclose and information regarding it to any unauthorized person, or to incorporate this data into any other design or use thereof. All patent rights are expressly reserved.