

# ETERNALIGHT MINI

## STAND-BY EMERGENCY LIGHTING INVERTER

KEEP THE LIGHTS "ON" WHEN YOU NEED THEM THE MOST

SINGLE PHASE 350 W - 2000 W

Defends your environment against unwanted power outage and electrical disturbances by providing:

- DSPM Watchdog software always on guard.
- Display monitor keeps you in control 24/7.
- Dependable DSP/PWM technology for unsurpassed reliability.
- Economical for the lowest overall cost for your light safety with an Energy Star Rating.
- Temperature compensating technology that controls batteries for the longest battery life.
- Sealed maintenance-free batteries.
- Full light output for entire 90 minutes.
- Self-diagnostics for a safe and secure lighted environment.
- Pure sine wave output for all types of lamps.
- ECM module is a patented technology used by DSPM.
- Backup solutions for multiple applications such as: indoor and outdoor emergency lighting, exits, cash registers, computers, strategic electronics, and more!
- 10 Year pro-rated battery warranty.
- 5 Year power train warranty.
- Listed to UL924, UL1778, UL508
- Cities of Chicago and New York approved.
- Complies with the Buy American Act.

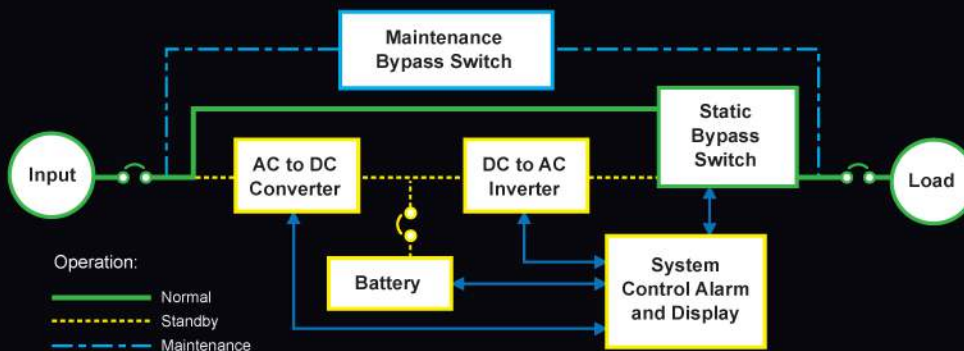

**DSPM** INC.  
DIGITAL SIGNAL POWER MANUFACTURER  
www.dspmanufacturing.com

1921 S. Quaker Ridge Place  
Ontario, CA 91761  
1.877.DSPM POWER  
1.877.377.6769  
Fax: 909.930.3335



# ETERNALIGHT MINI

## STAND-BY EMERGENCY LIGHTING INVERTER

KEEP THE LIGHTS "ON" WHEN YOU NEED THEM THE MOST

SINGLE PHASE 350 W - 2000 W

350, 525, 700, 750, 875, 1050, 1400, and 2000 Watts.....Standard Power Levels  
 120, 208, 240, 277 or 480 VAC.....Input Voltage  
 +10% -15%.....Input Voltage Range  
 120, 277, 480, 120/240 or 120/277 VAC.....Output Voltage  
 ±2% for all loads and battery discharge mode.....Output Voltage Regulation  
 60 Hz, ±1%.....Output Frequency Range  
 Sine-wave <5% @ 100% linear load.....Output Wave Form  
 2.5:1 typical.....Crest Factor  
 Input Main Circuit Breaker.....Input Protection  
 Output Main Circuit Breaker.....Output Protection  
 The unit will protect itself and the load.....Surge Protection  
 against surges as defined in  
 ANSI/IEEE C62.45 Category A and B  
 Sealed maintenance-free (AGM) lead calcium.....Battery  
 Conforms to UL924 standards.....Recharge Current  
 Provision for hardware connection of.....External Battery  
 external battery cabinets or DC source  
 ≥92% at 100% linear load.....Efficiency  
 <45dB measured on Response Curve "A".....Audible Noise  
 UL924 and UL1778.....ETL Listed  
 0° to 40°C (32° to 104°F).....Operating Temperature  
 -20° to 60°C (-4° to 140°F).....Storage Temperature  
 5 - 95%, Non-condensing.....Humidity



### Options:

ECM - Environmental Control Module  
 NOF - Normally OFF Circuit  
 NOH - Normally OFF "Hold On"  
 OCB - Output Circuit Breker(s)  
 EPO - Emergency Power Off  
 RSSP - Remote Indicatoor Panel  
 SNMP - SNMP Card  
 FC - Form C Contacts  
 SRB - Seismic-Rated Bracket  
 STU1 - Onsite Startup  
 IDB - Internal Dimmer Bypass  
 EMB - External Maintenance Bypass  
 EW - Extended Warranty

Specifications subject to change without notice.

Mini Series	Power Rating	UPS Cabinet Dimensions			Weight (lbs)
		W	H	D	
SEMIMI (Consult factory for others)	VA/W	W	H	D	(lbs)
	350	24"	26"	16"	340
	525	24"	26"	16"	340
	700	24"	26"	16"	370
	750	24"	26"	16"	370
	875	24"	26"	16"	370
	1050	24"	26"	16"	440
1400	24"	26"	16"	460	
2000	24"	26"	16"	600	

Represented By:



1921 S. Quaker Ridge Place  
 Ontario, CA 91761  
 1.877.DSPM POWER  
 1.877.377.6769  
 Fax: 909.930.3335