



STAND-BY ETERNALIGHT MICRO ELITE

SPECIFICATIONS

- The Stand-By Eternalight Micro Elite maintains efficient AC Emergency Power to operate all emergency lighting fixtures at “full-light” output after the transfer is complete, providing superior dependability and security to commercial/industrial environments in a small footprint.

POWER RATING

- 525 Watts - 1050 Watts single phase output unit uses the latest DSP/PWM technology to provide the most advanced performance and reliability features.

DIAGNOSTICS AND MAINTENANCE

- DSP/PWM technology and DSPM Watchdog Software provides complete self diagnostic capabilities and LCD Monitoring
- Informative advanced Display and Alarms keep you in control of your emergency lighting environment 24/7
- Automatically performs periodic self-tests ensuring a safely lighted environment prior to an emergency
- Single point of testing instead of multiple testing points with battery packs

INPUT

- 120V or 277, 208, 240, 480 VAC input 60Hz

OUTPUT

- 120V or 277, 240, 120/240, 120/277 VAC.
Stand-by design is ≥99% efficient at 100% linear load

PROTECTION

- Provides overload, surge and undercurrent protection using DSP/PWM technology and DSPM Watchdog Software to protect system performance and reliability
- Transfer in 16msec - 60msec

BATTERIES

- Sealed, maintenance-free, lead calcium (AGM) batteries
- 10-Year prorated warranty
- DSP/PWM Smart Battery Monitoring System is TEMPERATURE COMPENSATED maintaining maximum runtime and battery life
- Microprocessor controlled recharge and DSP/PWM overcharge protection standard

INSTALLATION

- Modular design and small footprint allow easy installation in electrical closet or other convenient locations
- Phone assisted factory start-up standard for all systems
- Extended warranty available

LAMPS AND LOADS

- Emergency power provides FULL LIGHT OUTPUT from all lamps and fixtures for the entire runtime
- Operates fluorescent, compact fluorescent, incandescent, quartz, LED and other lamp types
- Standard or electronic ballasts, dimming devices or panels, sensors and most control equipment
- Standard or LED Exits and other safety equipment

CODES

- UL 924, UL 1778, meets NFPA 101, NFPA 70, NEC and OSHA standards
- Cities of Chicago, New York, and Los Angeles approved
- Complies with the Buy American Act

WARRANTY

- 1-Year full warranty on system electronics
- Battery warranty 1-year with 9-years pro-rated
- System 1-year on-site warranty labor with DSPM phone assisted start-up
- 5-Year powertrain warranty
- Maintenance contracts available

SPECIAL APPLICATIONS

- DSPM offers numerous UL924 optional devices to meet unusual or difficult application parameters
- ECM - Environmental Circuit Module allows fixtures and lamps on the emergency circuit(s) to be operated by normal switching and/or dimming devices in NON-emergency conditions
- Dimming Panel Interface allows use with emergency lights controlled by common dimmer panel

CABINET

- Space saving small footprint
- Modular design enables flexible installation

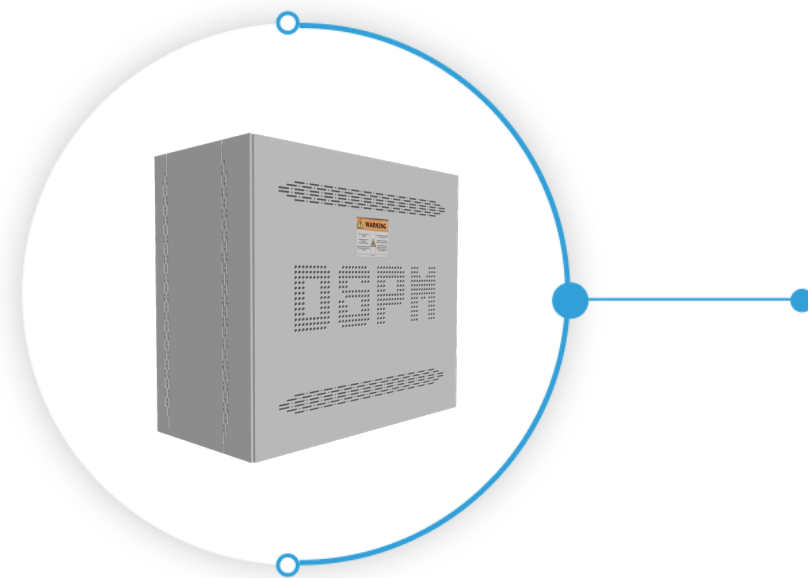

525 W - 1050 W
Single Phase
LED Compatible
Stand-By
Emergency
Lighting and
Power
Systems

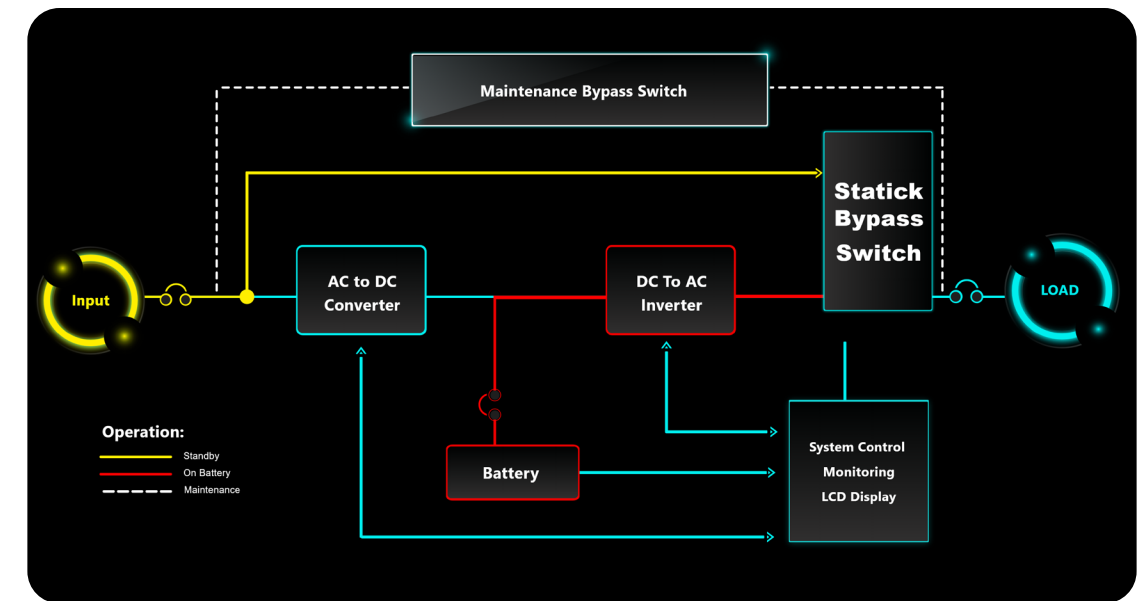

ELECTRICAL SPECIFICATIONS

Input Voltage Range	+10% , -15%
Output Voltage Regulation	±2% for all loads and battery discharge mode
Output Frequency Range	60 Hz, ±1%
Output Wave Form	Sine-wave <5% @ 100% linear load
Crest Factor	2.5:1 typical
Input Protection	Input Main Circuit Breaker
Output Protection	Output Main Circuit Breaker
Surge Protection	The unit will protect itself and the load against surges as defined in ANSI/IEEE C62.45 category A and B
Efficiency	≥99% at 100% linear load
Audible Noise	<45dB measured on Response Curve "A"
Operating Temperature	0° to 40°C (32° to 104°F)
Storage Temperature	-20° to 60°C (-4° to 140°F)
Humidity	5 - 95%, Non-condensing
Monitoring	LED Display Alarms and Diagnostics
Transfer Time	16msec - 60msec

Eternalight Micro Series	Power Ratings	UPS			Weight	British Thermal Units	Battery Type	Voltage (VAC)		Output Protection	Safety Approvals
		Cabinet Dimensions						Input	Output		
SEMEL	VA/W	W	H	D	(lbs)	BTU's	Sealed, Maintenance free (AGM) lead calcium			Input and output circuit breakers standard	UL924 UL1778 NFPA 101 NFPA 70 NEC
	525	25"	22"	12"	157	17.8		<u>Select</u> 120	<u>Select</u> 120		
	700	25"	22"	12"	200	23.8		208	120/240		
	875	25"	22"	12"	200	29.8		240 or 277	or 277		
	1050	25"	22"	12"	207	35.7		408	120/277		

The Stand-By Eternalight Micro Elite provides the simplicity and reliability that is critical when providing an alternative source of power to any environment. Easy installation ..."simplicity"...connect the Micro Elite to the emergency circuit(s) and everything is backed up..."reliability"...during a power outage. All lighting connected to the Micro Elite will simply continue to operate at "full light output" once the transfer is complete. DSPM Watchdog® software keeps your environment safe while self-diagnostics help maintain equipment to a high standard. Superior surge suppression assures the highest quality of power being delivered to all loads, all the time.

We sincerely hope you never experience a real emergency, but if you do, you deserve the security, safety and peace of mind that the Stand-By Eternalight Micro Elite from DSPM ensures.

ORDERING INFORMATION

Choose the bold face catalog nomenclature that best suites your needs.

Write them on the appropriate line. Order accessories as separate catalog number.

Example:

SEMEL - 525 - 120/120 - NOF/120/1

Description of example:

(525 Watt, 120 Voltage In, 120 Voltage Out, 1 Normally Off 120 Volt Output Circuit)

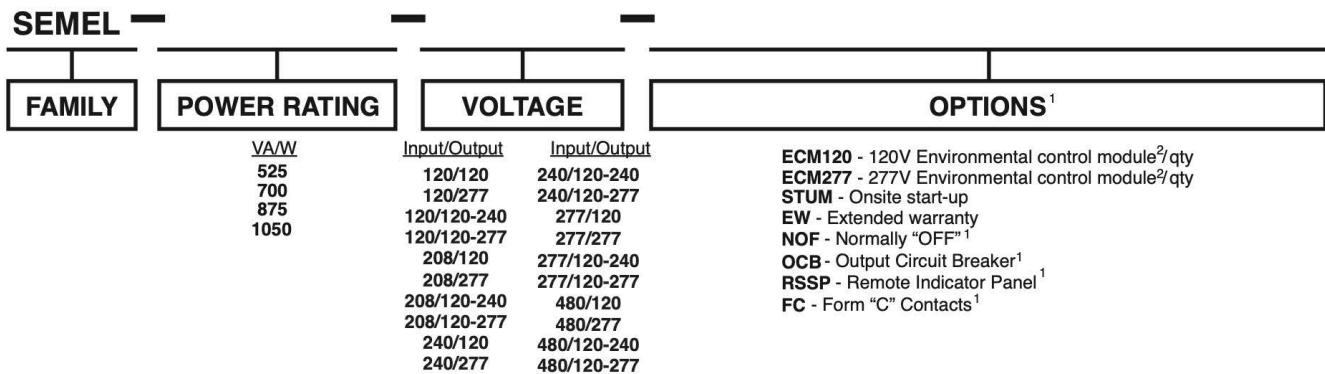

NOTES:

1-Combination of options may be limited. Please contact factory.

2-One ECM is used per switching device or circuit.

Specifications subject to change without notice.

MECHANICAL FOOTPRINT

Top View

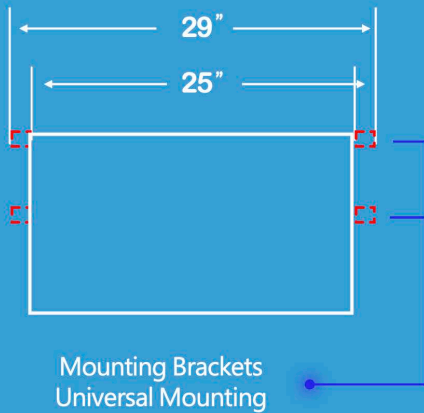

Mounting Brackets
Universal Mounting

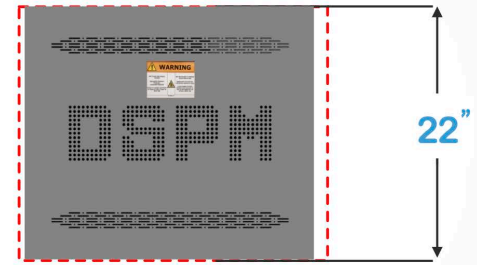

Front View

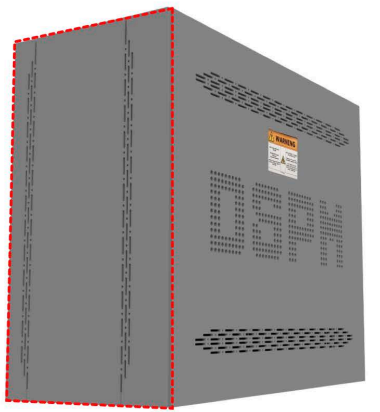

Right/Left Side View

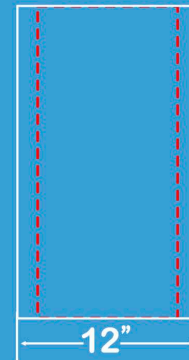

The Micro comes with mounting brackets that can be placed either in the front or back of the unit.

Notice: This drawing contains confidential and proprietary data originated. All design, manufacturing, reproduction, use and sale rights are expressly reserved. The recipient agrees by accepting this document, not to supply or disclose and information regarding it to any unauthorized person, or to incorporate this data into any other design or use thereof. All patent rights are expressly reserved.