



# Maintenance Manual

Maintenance Manual #074-3003-AEC

Fortress 1: 0.35KW to 7.0KW

Emergency Lighting Inverter

# TABLE OF CONTENTS

TABLE OF CONTENTS -----	2
REVISION HISTORY -----	4
REPRODUCTION OR DISTRIBUTION -----	5
ABOUT THIS MANUAL -----	6
SECTION HOW TO USE THIS MANUAL	
SECTION TECHNICAL ASSISTANCE	
IMPORTANT SAFETY INSTRUCTIONS -----	8
SECTION NOTES AND SAFETY INFORMATION	
CHAPTER 1 INTRODUCTION -----	12
SECTION 1.1. GENERAL	
SECTION 1.2. DEFINITIONS	
SECTION 1.3. THEORY OF OPERATION	
SECTION 1.4. OUTPUT LOADS	
SECTION 1.5. OPTIONS	
SECTION 1.6. OVERVIEW	
FIGURE 1—SINGLE-LINE DRAWING	
SUBSECTION 1.6.A. NORMAL OPERATION	
FIGURE 2—SINGLE-LINE DRAWING-NORMAL OPERATION	
SUBSECTION 1.6.B MANUAL BYPASS OPERATION	
FIGURE 3—SINGLE-LINE DRAWING-MANUAL BYPASS	
SUBSECTION 1.6.C. AC LOSS/BATTERY OPERATION	
FIGURE 4—SINGLE-LINE DRAWING-AC LOSS/BATTERY OPERATION	
SUBSECTION 1.6.D. EXTERNAL MAINTENANCE BYPASS OPERATION (OPTIONAL)	
FIGURE 5—SINGLE-LINE DRAWING-EXTERNAL EXTERNAL MAINTENANCE BYPASS OPERATION	
CHAPTER 2 SPECIFICATIONS -----	19
TABLE 1 — SPECIFICATIONS	
SECTION 2.1. POWER RATING	
SECTION 2.2. INPUT	
SECTION 2.3. OUTPUT	
SECTION 2.4. BATTERIES	
SECTION 2.5. LAMPS AND LOADS	
SECTION 2.6. CODES	
SECTION 2.7. PROTECTION	
SECTION 2.8. DIAGNOSTICS AND MAINTENANCE	
SECTION 2.9. CABINET	
SECTION 2.10. INSTALLATION	
SECTION 2.11 SPECIAL APPLICATIONS	
SECTION 2.12. WARRANTY	
CHAPTER 3 FIELD REPLACEABLE UNITS (FRUS) -----	21
SECTION 3.1. MOTHER/MAIN BOARDS	
SECTION 3.2. ALL OTHER PARTS	

<b>CHAPTER 4 MAINTENANCE</b> .....	<b>22</b>
SECTION 4.1. SAFETY PRECAUTIONS	
SECTION 4.2. WHEN TO CALL	
SECTION 4.3. STEPS TO TAKE	
SECTION 4.4. PREVENTATIVE MAINTENANCE	
SUBSECTION 4.4.1. MAINTAINING AN OPERATOR'S LOG	
SUBSECTION 4.4.2. PERIODIC TESTING OF UPS	
SUBSECTION 4.4.3. MAINTAINING BATTERIES LOG	
FIGURE 6—RECOMMENDED BATTERIES TESTERS	
SUBSECTION 4.4.4. RECORDING ENTRIES IN THE BATTERIES LOG	
LOG 1—BATTERIES MAINTENANCE LOG	
LOG 2—OPERATOR'S MAINTENANCE LOG	
FIGURE 7—WATER DOTS DEMONSTRATION	
SUBSECTION 4.4.5. MAINTAINING THE BATTERIES	
SUBSECTION 4.4.6. CHARGING OF THE BATTERIES	
<b>CHAPTER 5 DISPLAYS</b> .....	<b>33</b>
SECTION 5.1. FRONT PANEL DESCRIPTION	
FIGURE 8—FRONT PANEL DISPLAY	
FIGURE 13—UPS OPERATION MODE	
TABLE 2—OTHER INDICATORS	
FIGURE 14—DISPLAY	
<b>CHAPTER 6 OPERATION AND PROCEDURE</b> .....	<b>35</b>
SECTION 6.1. START-UP PROCEDURE	23
SECTION 6.2. SHUT-DOWN PROCEDURE	
SECTION 6.3. BATTERY RUN AUDIBLE ALARM	
SECTION 6.4. LOW BATTERY (RAPID ALARM)	
<b>CHAPTER 7 SYSTEM OPTIONS</b> .....	<b>37</b>
SECTION 7.1. UNIT OPTIONS	
SECTION 7.2. SERVICE PROGRAM DESCRIPTIONS	
TABLE 3 — SERVICE COVERAGE	
<b>CHAPTER 8 APPENDIXES</b> .....	<b>45</b>
SECTION 8.1. FIGURES AND TABLES	
TABLE 4—TROUBLESHOOTING	
FIGURE 9—PERFORMIX PLASTI DIP PROCESS	
FIGURE 10—SYSTEM COMPONENT LAYOUT	
SECTION 8.1. LIMITED WARRANTY	
SECTION 8.2. NOTES	



## Reproduction or Distribution forbidden

NOTICE: THIS DOCUMENT CONTAINS PROPRIETARY INFORMATION

This document contains proprietary and confidential information of Digital Signal Power Manufacturer, Inc. ("Digital Signal Power Manufacturer"). In consideration of the receipt of this document, the recipient agrees not to copy any of its contents, nor to disclose them to or allow them to be used by any person not currently an Digital Signal Power Manufacturer employee or an employee of the recipient having a need to know, without the express written consent of Digital Signal Power Manufacturer, and further agrees to surrender this document to Digital Signal Power Manufacturer when the reason for its receipt has terminated.

© 2022 Digital Signal Power Manufacturer, Inc. - All rights reserved

## About this Manual

Thank you for selecting this Emergency Lighting Inverter System (ELI). It provides you with perfect protection for connected loads and equipment. This manual contains Important instructions that should be followed during maintenance of the DSPM Uninterruptible Power Supply. It includes important safety and maintenance instructions for operating the Emergency Lighting Inverter System. If you should have any problems with the Emergency Lighting Inverter System, please refer to this manual and/or call technical support.

Your DSPM Uninterruptible Power Supply is designed to provide reliable protection from power disturbances for many years. Please be sure to follow the manufacturers instructions to ensure optimum performance of the equipment. This manual contains descriptions of all controls and indicators required to operate the DSPM Uninterruptible Power Supply. Please read this manual carefully and retain it for future reference.

To the best of our knowledge and at the time written, the information contained in this document is technically correct and the procedures accurate and adequate to operate this instrument in compliance with its original advertised specifications. While every precaution has been made to ensure accuracy and completeness in this manual, DSPM assumes no responsibility and disclaims all liability for damages resulting from the use of this information or for any errors or omissions.

This instrument is designed to prevent accidental shock to the operator when properly used. However, no engineering design can render safe an instrument which is used carelessly. Therefore, this manual must be read carefully and completely before making any measurements. Failure to follow directions can result in a serious or fatal accident.

## How to use this Manual

This manual is designed for ease of use, giving the user easy and quick reference to information. This manual uses notice icons to draw attention to the user important information regarding the safe operation and installation of the UPS. The notice icons used in this manual are explained below, and should be taken into account and adhered to whenever they appear in the text of this manual.

## Technical Assistance

**Safety Recommendations:** If any problems are encountered while following this manual, DSPM assistance and correspondence is recommended. For technical support or help with any questions not covered in the manual, contact.



# DSPM

## DSPM Inc.

439 S Stoddard Ave,  
San Bernardino, CA 92410

Work Hours: 8 a.m. – 5 p.m. Pacific Standard Time

Phone: 1(877) DSPM POWER

1(877) 377-6769

After Hours: 5 p.m. – 1 a.m. Pacific Standard Time

1(951) 840-0811

Fax: 1(909) 930-3335

Email: [techsupport@dspmanufacturing.com](mailto:techsupport@dspmanufacturing.com)

Internet: <http://www.DSPManufacturing.com>

To expedite assistance if required, Please have the following information from your unit's System Label (found on the right side and inside door panel) available:

Model:	
Model Number:	
S/O Number:	
Input Voltage:	
Output Voltage:	
Power Rating and Frequency:	

# IMPORTANT SAFEGUARDS, READ AND FOLLOW ALL SAFETY INSTRUCTIONS SAVE THESE INSTRUCTIONS

## SECTION-SAFETY

### Notes and Safety Information:

Following safety precautions is important when operating or servicing electrical equipment. Always heed these precautions since they are essential to the safe operation and servicing of this product. This Manual contains 'warning symbols which alert the user to check for hazardous conditions. The symbols are used extensively throughout this manual and are defined below. To ensure the safety of operating performance of this electrical equipment, these instructions must be adhered to.



#### **WARNING:**

A Warning notice icon conveys information to protect the user and service personnel against hazardous conditions.



#### **DANGER:**

A Danger notice icon conveys that there is a risk of electric shock, personal injury, or death to the user if instructions are not followed.



#### **CAUTION:**

A Caution notice icon conveys to the user or service personnel information making them aware that there is a possibility of equipment damage.



#### **NOTE:**

A Note notice icon indicates when the user should make a reference of information regarding the UPS operation, load status and display status. Such information is essential if DSPM, Inc. field service assistance and correspondence is required.



#### **CAUTION!**

ENSURE THAT NO FLUIDS OR OTHER FOREIGN OBJECTS CAN ENTER THE INVERTER SYSTEM.



#### **NOTE!**

READ THIS MANUAL IN ITS ENTIRETY BEFORE PERFORMING THE INSTALLATION, START-UP, OPERATION, OR MAINTENANCE OF THE UPS (Uninterruptible Power System) OR BATTERY SYSTEMS. FAILURE TO DO SO COULD RESULT IN ELECTROCUTION, FIRE, EXPLOSION, OR EQUIPMENT FAILURE.



 **WARNING!**

ONLY FACTORY TRAINED OR AUTHORIZED PERSONNEL SHOULD ATTEMPT TO INSTALL OR REPAIR THE UPS OR ITS BATTERY SYSTEM. IMPROPER INSTALLATION HAS PROVEN TO BE THE SINGLE MOST SIGNIFICANT CAUSE OF START-UP PROBLEMS. HIGH AC AND DC ELECTRICAL VOLTAGES ARE PRESENT THROUGHOUT THE UNIT(S) AND INCORRECT INSTALLATION OR SERVICING COULD RESULT IN ELECTROCUTION, FIRE, EXPLOSION, OR EQUIPMENT FAILURE.

 **CAUTION!**

ALL POWER CONNECTIONS MUST BE COMPLETED BY A LICENSED ELECTRICIAN WHO IS EXPERIENCED IN WIRING THIS TYPE OF EQUIPMENT. WIRING MUST BE INSTALLED IN ACCORDANCE WITH ALL APPLICABLE NATIONAL AND LOCAL ELECTRICAL CODES. IMPROPER WIRING MAY CAUSE DAMAGE TO THE EQUIPMENTS, INJURY OR DEATH OF PERSONNEL. VERIFY THAT ALL HIGH AND LOW VOLTAGE INPUT POWER CIRCUITS ARE DE-ENERGIZED AND LOCKED OUT BEFORE INSTALLING CABLES OR MAKING ANY ELECTRICAL CONNECTIONS.

 **NOTE!**

THIS EQUIPMENT GENERATES, USES, AND CAN RADIATE RADIO FREQUENCY ENERGY, AND, IF NOT INSTALLED AND USED IN ACCORDANCE WITH THIS MANUAL, MAY CAUSE INTERFERENCE TO RADIO COMMUNICATIONS. IT HAS BEEN TESTED AND FOUND TO COMPLY WITHIN THE LIMITS FOR A COMPUTING DEVICE PURSUANT TO SUB PART J OF PART 15 OF FCC RULES, WHICH ARE DESIGNED TO PROVIDE REASONABLE PROTECTION AGAINST SUCH INTERFERENCE WHEN OPERATED IN A COMMERCIAL ENVIRONMENT.

 **DANGER!**

LETHAL VOLTAGES EXIST WITHIN THE EQUIPMENT DURING OPERATION. EXTREME CAUTION IS REQUIRED WHEN PERFORMING MAINTENANCE OBSERVE ALL WARNINGS AND CAUTIONS IN THIS MANUAL. FAILURE TO COMPLY MAY RESULT IN SERIOUS INJURY OR DEATH. OBTAIN QUALIFIED SERVICE FOR THIS EQUIPMENT AS INSTRUCTED.

 **DANGER!**

BE CONSTANTLY AWARE THAT THE UPS SYSTEM CONTAINS HIGH DC AS WELL AS AC VOLTAGES. WITH INPUT POWER OFF AND THE BATTERY, DISCONNECTED, HIGH VOLTAGE AT THE FILTER CAPACITORS AND POWER CIRCUITS SHOULD DISCHARGE WITHIN 30 SECONDS. HOWEVER, POWER CIRCUIT FAILURES CAN OCCUR, SO YOU SHOULD ALWAYS ASSUME THAT HIGH VOLTAGE MIGHT STILL EXIST 30 SECONDS AFTER SHUTDOWN. VERIFY THAT POWER IS OFF USING AC AND DC VOLTMETERS BEFORE MAKING CONTACT.

 **DANGER!**

SOME COMPONENTS WITHIN THE CABINETS ARE NOT CONNECTED TO CHASSIS GROUND. ANY CONTACT BETWEEN FLOATING CIRCUITS AND THE CHASSIS IS A LETHAL SHOCK HAZARD.

 **DANGER!**

OBSERVE ALL BATTERY SAFETY PRECAUTIONS DURING SERVICE OF THE UPS OR BATTERIES. EVEN WITH THE BATTERY CIRCUIT BREAKER IN THE OFF POSITION, THE DANGER OF ELECTROCUTION MAY STILL BE PRESENT. THE BATTERY POWER TO THE UNIT MUST BE LOCKED AND TAGGED “OFF” BEFORE PERFORMING ANY SERVICE OR WORK ON THE UNIT. FAILURE TO FOLLOW THOSE INSTRUCTIONS AND THE INSTRUCTION LISTED ABOVE AND ELSEWHERE IN THIS MANUAL COULD RESULT IN AN EXPLOSION, FIRE, EQUIPMENT FAILURE, OR ELECTROCUTION.

 **CAUTION!**

EXERCISE EXTREME CARE WHEN HANDLING UPS AND BATTERY CABINETS TO AVOID EQUIPMENT DAMAGE OR INJURY TO PERSONNEL. CABINETS WEIGH SEVERAL HUNDRED POUNDS.

 **CAUTION!**

TEST LIFT AND BALANCE THE CABINETS BEFORE MOVING. MAINTAIN Fortress 1MUM TILT FROM VERTICAL AT ALL TIMES. THE BOTTOM STRUCTURE WILL SUPPORT THE UNIT ONLY IF THE FORKLIFT FORKS ARE COMPLETELY UNDERNEATH THE UNIT.

 **CAUTION!**

INTERNAL BATTERY STRAPPING MUST BE SECURED BY THE CUSTOMER PRIOR TO CONNECTING THE BATTERY CABINETS TO THE UPS UNIT. THIS UNIT CONTAINS NON-SPILLABLE BATTERIES. KEEP THE UNIT UPRIGHT. DO NOT STACK. DO NOT TILT. ALWAYS FOLLOW THE BATTERY MANUFACTURER’S SAFETY INFORMATION TO PREVENT AN ACCIDENT THAT COULD RESULT IN INJURY OR DEATH. WILL SUPPORT THE UNIT ONLY IF THE FORKLIFT FORKS ARE COMPLETELY UNDERNEATH THE UNIT.

 **WARNING!**

LEAD-ACID BATTERIES CONTAIN HAZARDOUS MATERIALS. BATTERIES MUST BE HANDLED, TRANSPORTED, AND RECYCLED OR DISCARDED IN ACCORDANCE WITH FEDERAL, STATE, AND LOCAL REGULATIONS. BECAUSE LEAD IS A TOXIC SUBSTANCE, LEAD-ACID BATTERIES SHOULD BE RECYCLED RATHER THAN DISCARDED. DO NOT DISPOSE OF BATTERIES IN A FIRE, THE BATTERIES MAY EXPLODE. DO NOT OPEN OR MUTILATE THE BATTERIES. RELEASED ELECTROLYTE IS HARMFUL TO THE SKIN AND EYES AND MAY BE TOXIC. A BATTERY CAN HAVE A HIGH SHORT CIRCUIT CURRENT AND PRESENT A RISK OF ELECTRICAL SHOCK. THE FOLLOWING PRECAUTIONS SHOULD BE OBSERVED WHEN WORKING ON BATTERIES:

1. REMOVE WATCHES, RINGS OR OTHER METAL OBJECTS.
2. USE TOOLS WITH INSULATED HANDLES.
3. WEAR RUBBER GLOVES AND BOOTS.
4. DO NOT LAY TOOLS OR METAL PARTS ON TOP OF BATTERIES.
5. DISCONNECT CHARGING SOURCE PRIOR TO CONNECTING OR DISCONNECTING BATTERY TERMINALS.
6. DETERMINE IF BATTERY IS INADVERTENTLY GROUNDED. IF SO, REMOVE THE SOURCE OF THE GROUND. CONTACT WITH ANY PART OF A GROUNDED BATTERY CAN RESULT IN ELECTRICAL SHOCK. THE LIKELIHOOD OF SUCH SHOCK WILL BE REDUCED IF SUCH GROUNDS ARE REMOVED DURING INSTALLATION AND MAINTENANCE.
7. LEAD-ACID BATTERIES CAN PRESENT A RISK OF FIRE BECAUSE THEY GENERATE HYDROGEN GAS. THE FOLLOWING PROCEDURES SHOULD BE FOLLOWED:
  - DO NOT SMOKE WHEN NEAR BATTERIES.
  - DO NOT CAUSE FLAME OR SPARK IN BATTERY AREA.
8. DISCHARGE STATIC ELECTRICITY FROM YOUR BODY BEFORE TOUCHING BATTERIES BY FIRST

## CAUTION!

IN CASE OF FIRE INVOLVING ELECTRICAL EQUIPMENT. ONLY CARBON DIOXIDE FIRE EXTINGUISHERS, OR THOSE APPROVED FOR USE ON ELECTRICAL EQUIPMENT, SHOULD BE USED. USE OF WATER ON FIRES INVOLVING LIVE HIGH VOLTAGE ELECTRICAL CIRCUITS COULD PRESENT AN ELECTROCUTION HAZARD.

## DANGER!

TO REDUCE THE RISK OF ELECTRICAL SHOCK; DISCONNECT THE EMERGENCY LIGHTING INVERTER SYSTEM FROM THE MAIN SUPPLY BEFORE INSTALLING AN INTERFACE SIGNAL CABLE. RECONNECT THE POWER ONLY AFTER SIGNALING INTERCONNECTIONS HAVE BEEN MADE DO NOT DISMANTLE THE EMERGENCY LIGHTING INVERTER SYSTEM.

# 1. INTRODUCTION

## 1.1. GENERAL

The principles of operation described herein are applicable to all models. The DSPM, Inc. Fortress 1 Emergency Lighting Inverters are manufactured to provide critical power for lighting during a power outage. The Fortress 1 meets or exceeds the life safety codes of UL924 and UL1778. These codes were established to allow the emergency lighting inverters to provide critical power to the lighting circuits during a power failure. The emergency lighting inverter will then provide power for 90 minutes that will allow safe and orderly evacuation from the facility.

The product is an advanced Emergency Lighting Inverter System based on Intelligent Microprocessor Control. The Emergency Lighting Inverter System is an intelligent protector and provides pure, reliable AC power to the emergency loads – protecting them from utility power blackouts, swells, sags, surges and interference. All types of lamps are supported by our lighting inverter.

Under normal power conditions, this design enables the system to adjust and filter power fluctuations continuously and automatically. In the event of a power failure, it can immediately provide back-up power from the batteries without any interruption. When the utility power is connected or reconnected, the charger will automatically recharge the batteries.

When input power to The Fortress 1 is lost during a power outage, the system will automatically draw power from its internal battery supply without any interruption. The critical load will receive only clean sine wave power. The internal VRLA (valve regulated lead-acid), maintenance-free batteries provide 90 minutes of backup power.

Upon restoration of input power, The Fortress 1 automatically resumes normal operation, and immediately begins to recharge the batteries. The Fortress 1 has an internal bypass circuit, which maintains the power to the load in case of internal UPS failure.

The Advanced Battery Management system in this unit uses a Digital Signal Processing/Pulse-Width Modulation (DSP/PWM) Smart Battery Monitoring System for managing the system batteries. The DSP/PWM Smart Battery Monitoring System is temperature compensated resulting in maintaining maximum runtime and battery life. The microprocessor controls recharge and the DSP/PWM offer overcharge protection.

The Fortress 1 Online Emergency Lighting Inverter incorporates double-conversion technology that provides perfect protection specifically for Egress Lighting for facilities. It is designed to provide continuous and clean electrical power to a critical load. The load is powered by the inverter, which receives its power from the building source. In the event of an input power failure, the UPS will supply power to the critical load for the specified battery time.

The inverter uses a double-conversion principle eliminates all sources of unwanted power disturbances. A rectifier converts the alternating current from the building source to Direct Current (DC). This DC charges the batteries and powers the inverter. With the basic DC voltage, the inverter generates a sinusoidal alternating current (AC) voltage, which continuously supplies the load. In times of power outages, the 90-minute backup time that come standard in our units keep the load energized. If the input power is not restored promptly, backup power from the UPS battery permits the orderly shutdown of equipment supported by the UPS. The UPS is simple to start up, operate and maintain.

The Fortress 1 is an Stand-By PWM inverter available in multiple output rating. It is listed for compliance to UL1778, UL924, UL924A and CSA107.1 standards. The Micro is available with a variety of input or output voltages and power configurations.

This information is provided on the System Labels located on the inside front door and the right side of the UPS. See Chapter 2 for a complete listing of The Fortress 1 specifications.

This manual provides an overview of The Fortress 1 components and their functions. The appearance and purpose of operator controls and indicators is described with procedures for installation, operation, start-up, and shutdown.

## 1.2. DEFINITIONS

**1.2.1. UNINTERRUPTIBLE POWER SUPPLY SYSTEM (UPS)** - All components within the UPS Module Cabinet and associated batteries, which function as a system to provide continuous, conditioned AC power to a load.

**1.2.2. UPS MODULE CABINET** - The metal enclosure which contains the Rectifier / Charger, Inverter, Static Transfer Switch, Internal Bypass line, operator controls, batteries (up to 30kVA models only) and internal control systems required to provide specified AC power to a load.

**1.2.3. UPS MODULE** - The Rectifier / Charger and Inverter assemblies which, under the direction of the internal control system and operator controls, provide specified AC power to a load.

**1.2.4. RECTIFIER / CHARGER** - The UPS components which contain the equipment and controls necessary to convert input AC power to regulated DC power required for battery charging and for supplying power to the Inverter.

**1.2.5. INVERTER** - The UPS components which contain the equipment and controls necessary to convert DC power from the Rectifier / Charger, or the battery, to AC power required by the critical load.

**1.2.6. STATIC TRANSFER SWITCH** - The device that connects the critical load to the bypass line when the Inverter cannot supply continuous power.

**1.2.7. BYPASS LINE** - The line, which conducts electricity directly from the input power source to the critical load during Maintenance or whenever the UPS is not completely operational.

**1.2.8. AC INPUT POWER** - Is the power provided by the electrical utility company, or auxiliary generator, which is connected to the UPS for supplying the critical load and recharging the battery.

**1.2.9. BATTERY** - The rechargeable battery strings that supply DC power to the inverter to maintain continuous AC power to the load during AC input power failure conditions.

## 1.3 THEORY OF OPERATION

### 1.3.1. Standby Mode

After power is applied, the system is placed in STANDBY mode and a self-check starts. During this period, the start subroutine checks for the input voltage and proper operation of the inverter and bypass SCR's. After the routine is completed and check confirmed OK, the system stays in bypass waiting for the utility to fail. When a power outage occurs, the load is transferred to the inverter.

### 1.3.2. Online Mode

The input contactor K1 receives a closing signal, connecting input power to the DC supply transformer. The DC rectifier supplies the battery charger, Control Board and the DC/AC inverter circuit. The battery charger is then activated allowing the batteries to be continuously charged. The on-line DC/AC inverter converts the DC voltage to a pulse-width-modulation (PWM) waveform. This waveform is filtered and reconstructed to a desired AC output and the load is transferred to the inverter.

### 1.3.3. Response To Input Power Failure For An Online System

When the input power fails, the charger is turned off and the battery bank becomes a DC supply source to the inverter circuit, maintaining an uninterrupted AC supply to the protected load. When the facility power returns, stabilizes and is in phase with the backup power, the system controller closes the input contactor and the system returns to the Online mode. If the battery voltage drops below 26% of its nominal value and the facility power remains off, then the system will assume a FAILURE mode.

### Response To Input Power Failure For A Standby System

When the input power fails, the charger is turned off and the battery bank is transferred, becomes a DC supply source used to drive the inverter circuit, maintaining a uninterrupted AC supply to the protected load. When the facility power returns, stabilizes and is in phase with the backup power, the system controller closes the input contactor and the system returns to the Standby mode. If the battery voltage drops below 26% of its nominal value and the facility power remains off, then the system will assume a FAILURE mode.

### 1.3.4. UPS Failure

The System controller will issue a FAILURE message if any of the following conditions happen:

- Internal failure
- System overheats
- Battery bank under voltage

During a FAILURE, the system stops its backup operation, inverter SCRs are switched OFF, and bypass SCRs are switched ON. A summary alarm signal is sent to the hardwired interface. The system remains in this mode until power is cycled or system has been repaired when needed.

### 1.3.5. UPS Problem

The System controller will issue a UPS PROBLEM message if any of the following conditions occur:

- Input power failure
- Output overload

During a PROBLEM mode, inverter IGBTs remain on and an alarm signal may be sent to the signal interface.

The system will reset itself as soon as the problems disappears.

## 1.4. OUTPUT LOADS

The Fortress 1 is designed to power any lighting system. There are, however, certain types of loads that exhibit an excessive inrush current when first turned on or at other times during operation.

The capacity of the Fortress 1 may need to be greater than what would be estimated based on the system label requirements of loads previously discussed. Contact the factory directly if you have any questions about powering unusual loads from your Fortress 1 inverter.

## 1.5. OPTIONS (See Unit Options for details)

The following options are available with the Fortress 1 inverter:

- ECM120, ECM208, and ECM277—Environmental Control Module
- NOF—Normally OFF Circuit 120Vac or 277Vac
- NOH—Normally OFF “Hold On” Circuit 120Vac or 277Vac
- OCB—Output Circuit Breaker/(s) 120Vac or 277Vac
- EPO—Emergency Power Off
- RSSP—Remote Indicator Panel
- SNMP—SNMP Card
- MODBUS—Modbus TCP/IP Bridge
- FAX—Fax Modem
- MB—Modbus Interface
- FC—Form C Contacts
- STU3—Onsite Startup
- EW—Extended Warranty

## 1.6. OVERVIEW.

The UPS provides two power paths between the utility source and the critical load (Figure 1). Figure 2 shows the path for normal operation, with the load powered from the inverter. Figure 1 shows the path for bypass operation, with the load supplied through the static bypass line. The Input circuit breaker (MCCB) for protection of the UPS and cables are field supplied and field installed.

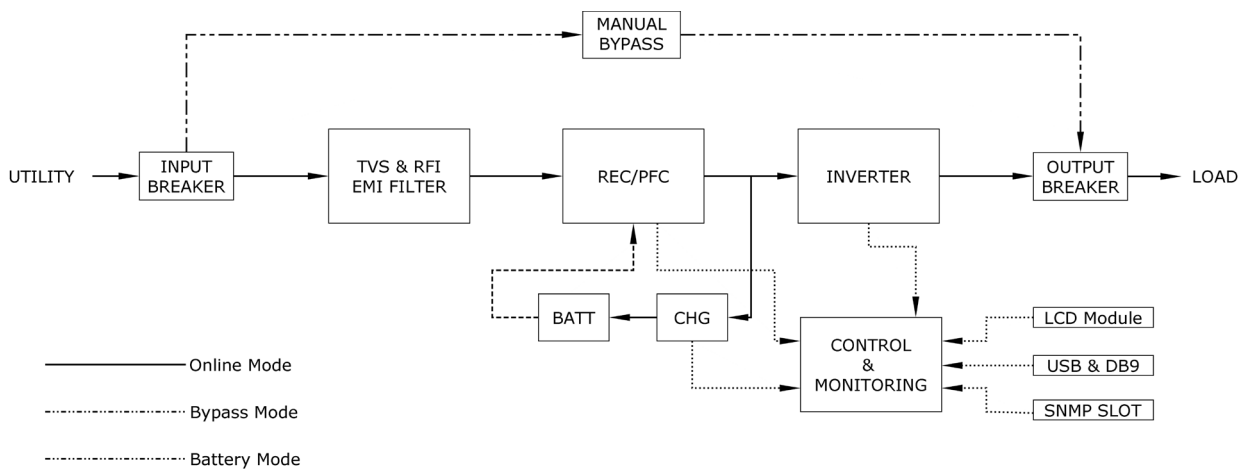

Figure 1 Single line Drawing

### 1.6.A. Normal Operation

During normal operation, the path through the inverter is used to power the load. Referring to Figure 2: two rectifiers convert Input AC power to DC. DC power is utilized to charge the UPS battery system (AC to DC Rectifier). The Inverter also convert AC to DC (Rectifier) to be able to generate clean AC power to supply the critical load. The conversion - inversion process eliminates any voltage transients or fluctuations existing in the input power before it reaches the critical load.

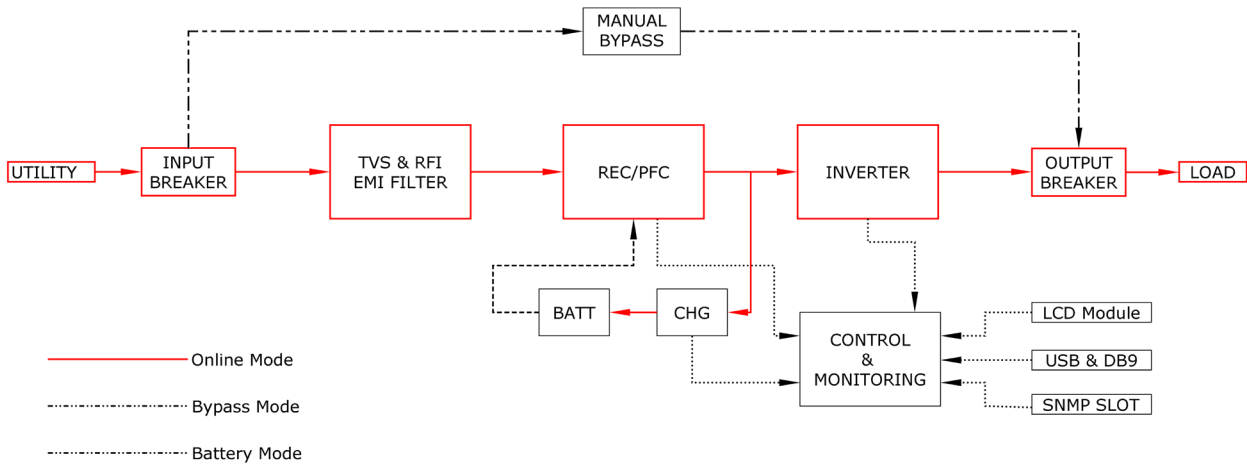

Figure 2 Single Line Drawing - Normal Operation

### 1.6.B. MANUAL BYPASS OPERATION

Refer to Figure 3. A Manual Bypass Switch is provided as a standard feature of the DSPM's UPS. This switch is to bypass the inverter logic incase of failure, to enable the end user function until service can be performed. The advantage of this form of bypass is that the input filtering is still providing protection to the critical loads on the UPS. Figure 3 illustrates the flow diagram when the UPS has been manually bypassed.

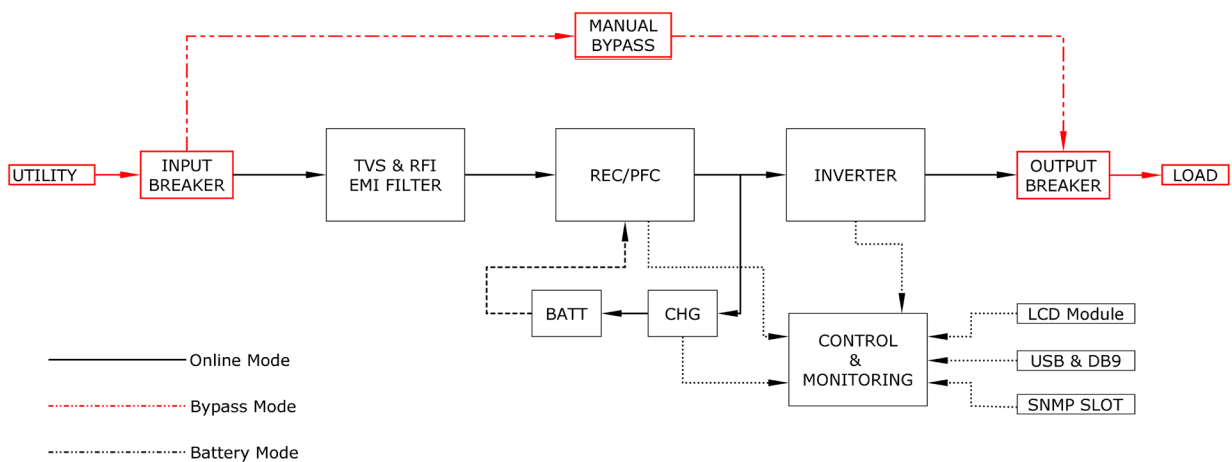

Figure 3 Single Line Drawing - Static Bypass Operation



### 1.6.C. AC Loss/Battery Operation

Referring to Figure 4, if the input power is interrupted, the battery will immediately supply the DC power required by the Inverter to maintain continuous AC power to the load. A fully charged battery will provide power for the specified time at the rated load, or longer at reduced load.

In the event of a power failure, the rectifiers will de-energize and the batteries will discharge into the Inverter and maintain power to the critical load until a) the battery capacity expires and the inverter turns off, or b) input power is restored after which the rectifiers will power the inverter and simultaneously recharge the batteries. Figure 4 illustrates the flow diagram during battery operation.

When power is restored after a low battery shutdown, the rectifiers automatically restart and, recharge the batteries and the Inverter is automatically restarted without operator intervention. The inverter automatically without operator intervention assumes the power from the Rectifier.

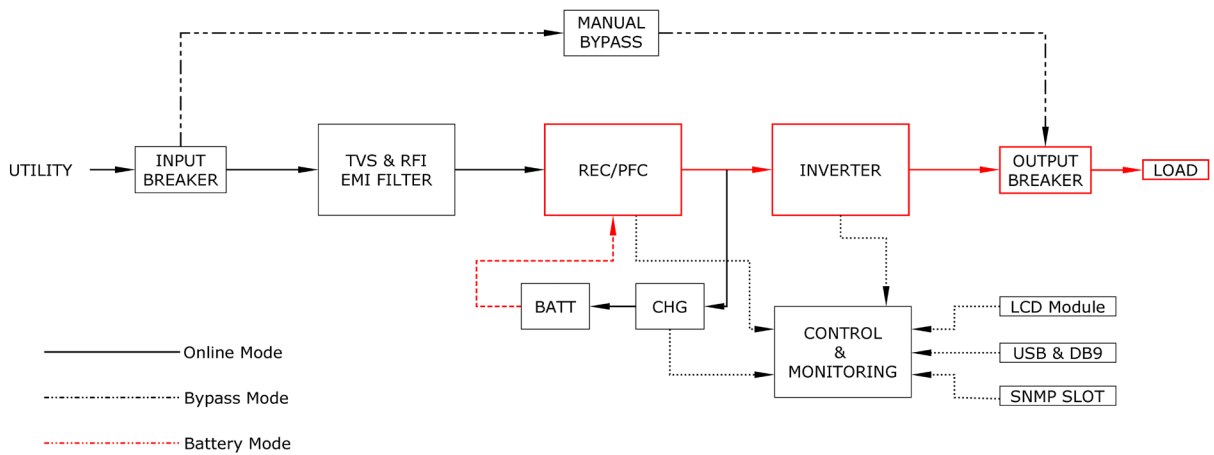

Figure 4 Single Line Drawing - AC Loss/Battery Operation

### 1.6.D. External Maintenance Bypass (EMB) Operation (Optional)

There is an optional External Maintenance Bypass which supplies the critical load with unconditioned input power. The purpose of this option is to route power to the critical load while the UPS' rectifier and inverter are de-energized, and during Start-up before the system is fully operational (refer to Figure 5).

With the External Maintenance Bypass there is a hard wired bypass that can be operated after the Static Bypass Switch has been operated, making it possible to isolate the entire UPS for service and maintenance. The internal control system determines the operation of the normal and External Maintenance Bypass paths, with the load powered from the inverter being the normal operation.

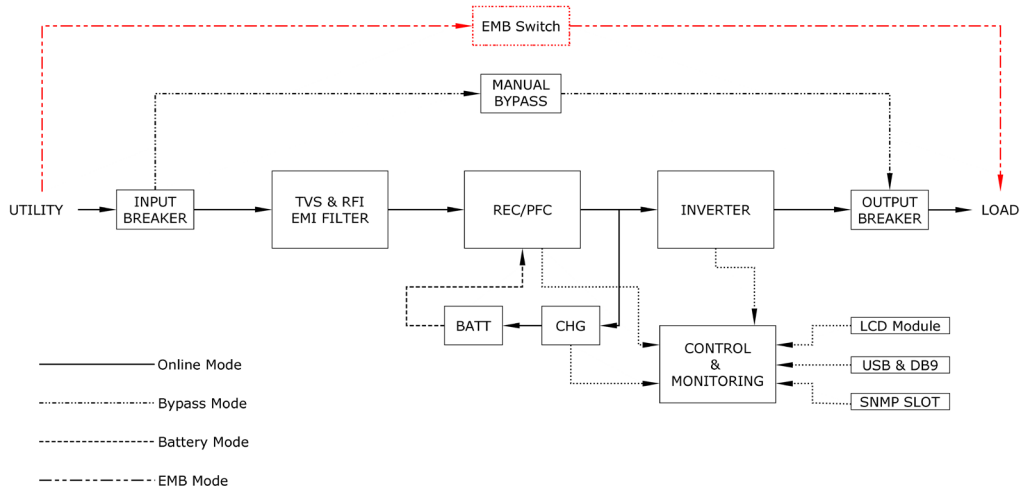

Figure 5 Single Line Drawing - External Maintenance Bypass Operation

## 2. SPECIFICATIONS

The Fortress 1 maintains efficient AC Emergency Power to operate all emergency lighting fixtures at “full-light” output, providing superior dependability and security to commercial/industrial environments in a small footprint. The UPS System Label displays the rated kW as well as nominal voltages. There are System Labels located on the interior side of the UPS front door and the exterior side of the unit. The power rating in Table 1 are kW values, when KVA is displayed on System Label, divide kVA in Table 1 by.8 for correct dimensions.

Mini Series	Power Rating	UPS			Battery			Weight (Com- bined)	British Thermal Unit	Battery Type	Voltage (VAC)		Input/ Output Protection	Safety Approvals
		Cabinet Dimensions			Cabinet Dimensions						Input	Output		
(Consult Factory For others)	KVA/ KW	W	H	D	W	H	D	(lbs)	BTU's	Sealed, Maintenance Free (AGM) Lead Calci- um	Select	Select	Input and Output Circuit Breakers standard	UL924 UL1778 NFPA 101 NFPA 70 NEC
	0.35	24"	26"	16"	Not required			340	11.9		120, 208, 240, 277, Or 480	120/ 240 Or 120/277		
	0.525	24"	26"	16"	Not required			340	17.85					
	0.7	24"	26"	16"	Not required			370	23.8					
	0.75	24"	26"	16"	Not required			370	25.5					
	0.875	24"	26"	16"	Not required			370	29.75					
	1.05	24"	26"	16"	Not required			440	35.7					
	1.4	24"	26"	16"	Not required			460	47.6					
2.0	24"	26"	16"	Not required			600	68						

Table 1

### 2.1. POWER RATING

The Fortress 1 units comes in power rating from 4.7 to 21.0 KW (Consult factory for other power ratings). They use the latest DSP/PWM technology to provide the most advanced performance and reliability features.

### 2.2. INPUT

120, 208, 240, 277 or 480 VAC input 60Hz

### 2.3. OUTPUT

120, 208, 277, 480, 120-240, or 120-277 VAC True “on-line” design is ≥95% efficient at 100% linear load

### 2.4. BATTERIES

2.4.1. Sealed, maintenance-free, lead calcium (AGM) batteries

2.4.2. 10-Year prorated warranty

2.4.3. DSP/PWM Smart Battery Monitoring System is TEMPERATURE COMPENSATED maintaining maximum runtime and battery life

2.4.4. Microprocessor controlled recharge and DSP/PWM overcharge protection standard

## 2.5. LAMPS AND LOADS

- 2.5.1. Emergency power provides FULL LIGHT OUTPUT from all lamps and fixtures for the entire runtime
- 2.5.2. Operates fluorescent, compact fluorescent, incandescent, quartz, H.I.D., LED and other lamp types
- 2.5.3. Standard or electronic ballasts, dimming devices or panels, sensors and most control equipment
- 2.5.4. Standard or LED Exits and other safety equipment

## 2.6. CODES

- 2.6.1. Meet UL 924, UL 1778, NFPA 101, NFPA 70, NEC and OSHA standards
- 2.6.2. Cities of Los Angeles, Chicago, New York approved
- 2.6.3. Complies with the Buy American Act

## 2.7. PROTECTION

- 2.7.1. Provides overload, surge and undercurrent protection using DSP/PWM technology to protect system performance and reliability
- 2.7.2. Surge protection against load surges as defined in ANSI/IEEE C62.45 category A and B

## 2.8. DIAGNOSTICS AND MAINTENANCE

- 2.8.1. DSP/PWM technology provides complete self diagnostic capabilities and LED Monitoring
- 2.8.2. Informative advanced Display and Alarms keep you in control of your emergency lighting environment 24/7.
- 2.8.3. Automatically performs periodic self-tests ensuring a safely lighted environment prior to an emergency. The power supplies are able to do a 5 minute battery run the first of every month except for New Year's day when the test is for 90 minute. The testing can be enabled by going to the Autorun screen and selecting Yes or No with the Menu Forward or Menu Reverse button. When the battery test happens the rectifier is turned off, and the batteries will sustain the load on the output. If the voltage dips too low the test is terminated prematurely, and a entry is recorded in the alarm log accordingly. Two minutes into the battery run test the voltage, power date, and time are logged in the battery log. This is a feature that is standard in our power supplies.
- 2.8.4. Single point of testing instead of multiple testing points with battery packs
- 2.8.5. Water Dots are placed on every shelf and door panel to indicate if moisture is present or has got inside the unit. The Dots are originally white in color but will turn red when water is absorbed.

## 2.9. CABINET

- 2.9.1. Modular design enables flexible installation
- 2.9.2. Forced air cooling for maximum reliability
- 2.9.3. All systems are self contained and require external battery cabinet (s)

## 2.10. INSTALLATION

- 2.10.1. Modular design and small footprint allow easy installation in electrical closet or other convenient locations
- 2.10.2. Phone assisted factory start-up standard for all systems
- 2.10.3. Extended warranty available

## 2.11. SPECIAL APPLICATIONS

- 2.11.1. DSPM offers numerous UL924 optional devices to meet unusual or difficult application parameters normal switching and/or dimming devices in NON-emergency conditions.
- 2.11.2. ECM - Environmental Circuit Module allows fixtures and lamps on the emergency circuit (s) to be operated by normal switching and/or dimming devices in NON-emergency conditions.
- 2.11.3. Dimming Panel Interface allows use with emergency lights controlled by common dimmer panel.

## 2.12. WARRANTY

- 2.12.1. One-Year full warranty on system electronics
- 2.12.2. Battery warranty 1-year with 9-years pro-rated
- 2.12.3. System 1-year on-site warranty labor with DSPM phone assisted start-up
- 2.12.4. Five-Year powertrain warranty
- 2.12.5. Maintenance contracts available

## 3. FIELD REPLACEABLE UNITS (FRUS)

Each FRUS comes with detail instructions of how the part should be performed. At the ends of most wires/cables are labels that indicates their locations. When ordering replacement parts from the factory, supply the information from the System Label (refer to Technical Assistance section in this manual). Include the model number, serial number, input/output voltages, and power rating when ordering parts. Replacement parts must be replaced by qualified factory trained service personnel only.

Circuit boards and IGBTs contain ESDS (Electro-Static Discharge Susceptible) components. Handle and package ESDS devices in accordance with JEDEC standard JESD625-A. Use a grounded ESD wrist strap when handling the devices and circuit boards. Always package components and circuit boards in static-dissipative plastic bags or the static-dissipative material that the FRUS came in before transporting (Even if a device has failed). Failure to do so could result in further damage, complicating repair and failure analysis.



### 3.1. MOTHER/MAIN BOARDS

The Mother/Main Boards are located on the three middle shelves and mounted with 10 screws. Verify that all connectors are matches with their designations and pins #1, 2, etc. Unplug jumper on daughter board and all connectors from on Mother Board. Install the new board. Reconnect all plugs and connections returning them to their original orientations.



**ALL PLUGS AND CONNECTIONS ARE NOT USED!**



### 3.2. All Other Parts

Verify that the cables are marked before disconnecting. Replace the defective part with the new part. Reconnect wiring the same way as it was disconnected.

## 4. MAINTENANCE

Factory-trained personnel should perform maintenance only. Factory training is available. Training can be done on-site, over the phone or at the factory. Various maintenance contracts are available; please contact “Customer Service” for more details.

### 4.1. SAFETY PRECAUTIONS



READ AND UNDERSTAND THIS SECTION THOROUGHLY BEFORE PERFORMING ANY MAINTENANCE WORK ON OR AROUND THE UPS. READ THE BATTERY MANUFACTURER’S MANUAL AND MATERIAL SAFETY DATA SHEETS BEFORE WORKING ON OR NEAR THE BATTERIES.

ONLY NORMAL SAFETY PRECAUTIONS ARE REQUIRED WHEN THE UPS IS OPERATING WITH ALL CABINET DOORS CLOSED. HOWEVER, THE UPS AND BATTERY CABINETS MUST BE KEPT FREE OF STANDING PUDDLES OF WATER, EXCESS MOISTURE, OR DEBRIS. DEBRIS CAN CONSIST OF EXCESSIVE DUST IN AND AROUND THE UNIT, AS THE COOLING FANS IN THE UPS WILL PULL THIS DUST INTO THE UNIT.



ONLY FACTORY TRAINED OR AUTHORIZED PERSONNEL SHOULD ATTEMPT TO INSTALL OR REPAIR THE UPS OR ITS BATTERY SYSTEM. IMPROPER INSTALLATION HAS PROVEN TO BE THE SINGLE MOST SIGNIFICANT CAUSE OF START-UP PROBLEMS. SERVICE PERSONNEL SHOULD WEAR INSULATING SHOES FOR ISOLATION FROM DIRECT CONTACT WITH THE FLOOR (EARTH GROUND), AND SHOULD MAKE USE OF RUBBER MATS WHEN PERFORMING MAINTENANCE ON ANY PORTION OF THE UNIT WHILE IT IS UNDER POWER. HIGH AC AND DC ELECTRICAL VOLTAGES ARE PRESENT THROUGHOUT THE UNIT(S) AND INCORRECT INSTALLATION OR SERVICING COULD RESULT IN ELECTROCUTION, FIRE, EXPLOSION, OR EQUIPMENT FAILURE.



SPECIAL SAFETY PRECAUTIONS AND LOCKOUT TAGOUT PROCEDURES ARE REQUIRED FOR ALL OPERATIONS INVOLVING THE HANDLING, INSTALLATION, OR MAINTENANCE OF THE UPS SYSTEM AND ANY ASSOCIATED BATTERY CABINETS. FAILURE TO FOLLOW SAFETY PROCEDURES COULD RESULT IN DEATH, INJURY OR DAMAGE TO EQUIPMENT.



THIS EQUIPMENT CONTAINS CIRCUITS THAT ARE ENERGIZED WITH HIGH VOLTAGES. ONLY TEST EQUIPMENT DESIGNED FOR TROUBLESHOOTING HIGH VOLTAGES SHOULD BE USED, PARTICULARLY FOR OSCILLOSCOPES AND PROBES.

ALWAYS CHECK WITH AN AC AND DC VOLTMETER TO ENSURE SAFETY BEFORE INITIATING CONTACT OR USING TOOLS. EVEN WHEN THE POWER IS OFF, DANGEROUSLY HIGH POTENTIAL VOLTAGES MAY EXIST AT CAPACITOR BANKS. ALWAYS OBSERVE BATTERY PRECAUTIONS WHEN OPERATING NEAR ANY BATTERIES. FAILURE TO OBSERVE THESE PRECAUTIONS COULD RESULT IN DEATH, INJURY OR DAMAGE TO EQUIPMENT.

## CAUTION!

OBSERVE ALL BATTERY SAFETY PRECAUTIONS DURING INSTALLATION OR SERVICE OF THE UPS OR BATTERIES. EVEN WITH THE BATTERY CIRCUIT BREAKER IN THE OFF POSITION, THE DANGER OF ELECTROCUTION MAY STILL BE PRESENT. THE BATTERY POWER TO THE UNIT MUST BE LOCKED AND TAGGED “OFF” BEFORE PERFORMING ANY SERVICE OR WORK ON THE UNIT. FAILURE TO FOLLOW THOSE INSTRUCTIONS AND THE INSTRUCTION LISTED ABOVE AND ELSEWHERE IN THIS MANUAL COULD RESULT IN AN EXPLOSION, FIRE, EQUIPMENT FAILURE, OR ELECTROCUTION.

## DANGER!

BE CONSTANTLY AWARE THAT THE UPS SYSTEM CONTAINS HIGH DC AS WELL AS AC VOLTAGES. WITH INPUT POWER OFF AND THE BATTERY, DISCONNECTED, HIGH VOLTAGE AT THE FILTER CAPACITORS AND POWER CIRCUITS SHOULD DISCHARGE WITHIN 30 SECONDS. HOWEVER, POWER CIRCUIT FAILURES CAN OCCUR, SO YOU SHOULD ALWAYS ASSUME THAT HIGH VOLTAGE MIGHT STILL EXIST AFTER SHUTDOWN. VERIFY THAT POWER IS OFF USING AC AND DC VOLTMETERS BEFORE MAKING CONTACT.

### 4.2. WHEN TO CALL

Call for service if you encounter any of the following conditions:

- 1) Repeated start-up attempts are unsuccessful.
- 2) A UPS fault occurs which cannot be cleared.
- 3) Normal operation of the critical load repeatedly causes an overload condition. This is not a UPS fault but a qualified person must analyze the total load connected to the UPS to prevent unit failure. Momentary overload conditions will be handled within the parameters of the UPS Unit but sustained overloads will cause the UPS Unit to fail.
- 4) Any indicators or alarms operate abnormally or continuously.
- 5) Any other abnormal function of the system occurs.
- 6) If any abnormal battery condition is detected.
- 7) When you are unsure of what action to take.

### 4.3. STEPS TO TAKE

If any of the above occur:

- 1) Record information off the System Label.
- 2) Call DSPM's Customer Service

## DANGER!

LETHAL VOLTAGES ARE PRESENT INSIDE THE EQUIPMENT EVEN WHEN THERE APPEARS TO BE NO INPUT POWER TO THE UNIT. PROTECT YOURSELF FROM THE RISK ELECTROCUTION BY REFERRING SERVICE TO QUALIFIED PERSONNEL ONLY.

## 4.4. PREVENTATIVE MAINTENANCE

UPS Operator Maintenance consists of the basic tasks listed in this section. Other maintenance functions require DSPM's service personnel.

### 4.4.1 Maintaining an Operator's Log

Every six months for the length of a Servicing Agreement the UPS system should be tested and measurement taken log in a Operator's/Maintenance Log. Failure to maintain a valid maintenance log could result in the voiding of all warranties. DSPM recommends the downloading and uses of the Maintenance log from [www.DSPMInc.net](http://www.DSPMInc.net) or [www.DSPManufacturing.com](http://www.DSPManufacturing.com). If you chose to use another log, the entries should contain the following information:

- Date of system start-up
- Dates that battery maintenance was performed
- Dates that input, output, and battery status readings were checked and the values displayed for these readings.
- Dates and summaries of all communications with DSPM's service personnel.

Careful record keeping will ensure proper maintenance of the UPS Unit, and assist in the correction of any abnormal conditions.

### 4.4.2 Periodic Testing of UPS

The UPS Unit should be manually exercised on a periodic basis (once every three months, for example). This forces the UPS unit to transfer to the battery and return to main power. This process activates self-diagnostic testing which may reveal conditions that require attention.

### 4.4.3 Maintaining Batteries Log

#### 4.4.3.A. Comprehensive Battery Maintenance Program

A comprehensive Battery Maintenance Program with the quarterly taking and recording of reading must be established and maintained for the life of the warranty period. Every three months for the length of the Servicing Agreement, the batteries should be tested and measurement taken log in a Batteries Maintenance Log. Failure to maintain a valid batteries log could result in the voiding of all warranties. DSPM recommends the uses and downloading (from: [www.DSPManufacturing.com](http://www.DSPManufacturing.com) or [www.DSPMInc.net](http://www.DSPMInc.net)) of the Batteries Log. If you chose to use another log, the entries should contain the entries in our recommended log (Please refer to the Batteries Maintenance Log in this manual when maintaining your Batteries Log.).

#### 4.4.3.B. Equipment

There are an array of battery resistance and capacity tester on the market (see Figure 5 for examples). We recommend the purchase of one that meets all the IEEE Standards for Stationary Battery Testing-CE Compliant. These type of testers allow for string testing under load, that is, they allow the necessary measurement to be taken without the system being taken off-line.



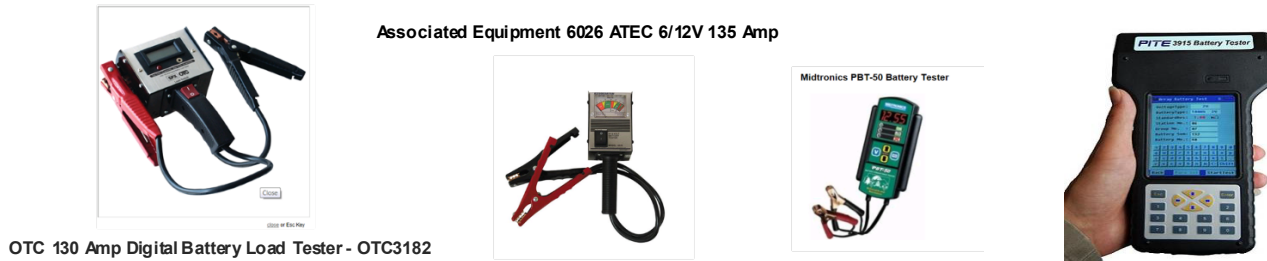

Figure 6

#### 4.4.3.C. Establishing Batteries Serial Numbers

Establish a system to identify individual batteries. Such a system that can be used is one that identifies the battery cabinet, each shelf, and each battery. Using either a clockwise

#### 4.4.4. Recording Entries in the Batteries Log

When you manually exercised the UPS, it is a good ideal to simultaneously complete the Battery Maintenance Log. The test that are made for the battery log, must be under load. This forcing of the UPS unit to transfer to the battery and return to main power would exercised the battery strings enough to provide the valid data necessary.

A sample of what goes into the cells of the Batteries Maintenance Log is found in Log 1. The following is a description of the entries necessary to complete the log.

##### 4.4.4.A. System Model # & SO #

These numbers are printed on your Sales Order (SO) form.

##### 4.4.4.B. Installation Date

This will be the date that you call

##### 4.4.4.C. Test Date

Is the start through completion date/s in which the batteries were tested.

##### 4.4.4.D. Location

The specific place in which the battery cabinet is located (i.e., 1st Floor, Data Building)

##### 4.4.4.E. Battery Model #

This information is printed on each battery. For example, U1-35 (12V35AH)

##### 4.4.4.F. # Batteries per string

The Battery Layout drawing on the door in your unit provides the number of batteries per string.

##### 4.4.4.G. Enclosure Temperature

Inside the battery cabinet temperature measured by technician when the cabinet is first opened after load test.

##### 4.4.4.H. Ambient Temperature

Outside the battery cabinet temperature measured by technician when the cabinet is first opened after load test.  
negative

#### 4.4.4.I. Float Voltage (V)

The no-load completely charged string voltage. This voltage will be taken across the top of the string breakers in the battery cabinet door.

#### 4.4.4.J. Float Current (A)

The no-load completely charged string current. This current will be taken with a DC clamp-on ammeter on either the or positive lead at the top of the string breakers in the battery cabinet door.

#### 4.4.4.K. Test Load (A) or (Watts)

Using an AC clamp-on ammeter, measure each phase output. This total is the Test Load amperage.

#### 4.4.4.L. Test end Voltage

When the 90 minute (what length of time it was ran) Battery Run was complete, measure DC Bus Voltage at the top of the Unit Battery Breaker

#### 4.4.4.M. Test Spec. Runtime

This is normally 90 minutes. Your unit specification runtime may be different. To find your unit's Runtime, refer to the Sales Order Form under Description.

#### 4.4.4.N. Test Actual Runtime

This time is the actual runtime that you ran the test.

#### 4.4.4.O. Serial #

Depending on the method you chose to identify your individual batteries, that identification became your Serial Number

#### 4.4.4.P. Voltage Under load

Is the individual voltage drop immediately after the Battery Run.

#### 4.4.4.Q. Ohmic Value

Also known as the internal resistance of the battery, Ohmic Value is the resistive value that the internal current encounters. This column takes the Voltage Under Load and the charging current immediately after the Battery Run and calculates the Ohmic Value. Some tester on the market will make this measurement for you.

#### 4.4.4.R. Battery Temp

Battery Temp = Enclosure Temperature +/-2°

#### 4.4.4.S. Observations

Non-Nominal reading or concerns about a specific battery should be noted here.

#### 4.4.4.T. Result

Non-Nominal reading or concerns about strings or cabinet connections should be noted here.

#### 4.4.4.U. Technician

The testing Technician should sign in this cell.

#### 4.4.4.V. Date

The testing Technician should Date the signing of his/her signature in this cell.

# BATTERIES MAINTENANCE LOG

System Model # & SO #: DW050361530-090V/051512-8a			Installation Date: 05/28/2020	
Test Date: 11/28/2020		Location: 1st Floor, Data Building		
Battery Model #: Power Source—U1-35/12V35AH		# Batteries per string: 20	Enclosure Temperature: 30°	
Float Voltage (V): 13.2/264.0 Vdc		Float Current (A): 0.7 Amp	Ambient Temperature: 25°	
Test end Voltage: 12.0/240 Vdc			Test Load (A) or (Watts): 60.2 Amp	
Test Spec. Runtime: 90 minutes			Test Actual Runtime: 30 minutes	
Serial #	Voltage Under load	Ohmic Value	Battery Temp	Observations
Battery #1	12.5 Vdc	7 mΩ	30°	
Battery #2	XXXXXX	XXX	XXX	
Battery #3	XXXXXX	XXX	XXX	
Battery #4	XXXXXX	XXX	XXX	
Battery #5	XXXXXX	XXX	XXX	
Battery #6	XXXXXX	XXX	XXX	
Battery #7	XXXXXX	XXX	XXX	
Battery #8	XXXXXX	XXX	XXX	
Battery #9	XXXXXX	XXX	XXX	
Battery #10	XXXXXX	XXX	XXX	
Battery #11	XXXXXX	XXX	XXX	
Battery #12	XXXXXX	XXX	XXX	
Battery #13	XXXXXX	XXX	XXX	
Battery #14	XXXXXX	XXX	XXX	
Battery #15	XXXXXX	XXX	XXX	
Battery #XX	XXXXXX	XXX	XXX	

Log 1

# BATTERIES MAINTENANCE LOG

System Model # & SO #:			Installation Date:	
Test Date:		Location:		
Battery Model #:		# Batteries per string:	Enclosure Temperature:	
Float Voltage (V):		Float Current (A):	Ambient Temperature:	
Test end Voltage:			Test Load (A) or (Watts):	
Test Spec. Runtime:			Test Actual Runtime:	
Serial #	Voltage Under load	Ohmic Value	Battery Temp	Observations
Battery #1				
Battery #2				
Battery #3				
Battery #4				
Battery #5				
Battery #6				
Battery #7				
Battery #8				
Battery #9				
Battery #10				
Battery #11				
Battery #12				
Battery #13				
Battery #14				
Battery #15				
Battery #XX				

Log 1 Cont.

# OPERATOR'S MAINTENANCE LOG

Model:	Location:	
Model Number:	S/O Number:	
Power Rating and Frequency:	Input Voltage:	Output Voltage:
Enclosure Temperature:	Ambient Temperature:	
Test Date:	Installation Date:	

## Initial Checks:

- Set the input Circuit Breaker and the Battery Breaker to the "Off" position.
- Remove all Voltage sources from system while doing the Initial Checks
- Visually check cabinets for signs of moisture. Check shelf's water dots (see Figure 7). Water dots are placed on every shelf and door panel to indicate if moisture is present or has got inside the unit. The Dots are originally white in color but will turn red when water drops are absorbed.
- Check cabinets for debris. If found, remove by blowing out cabinet with a non-moisture source.
- If unit has filter/s, remove and clean.
- Check that screws and hardware are secure
- Check wire and cable condition

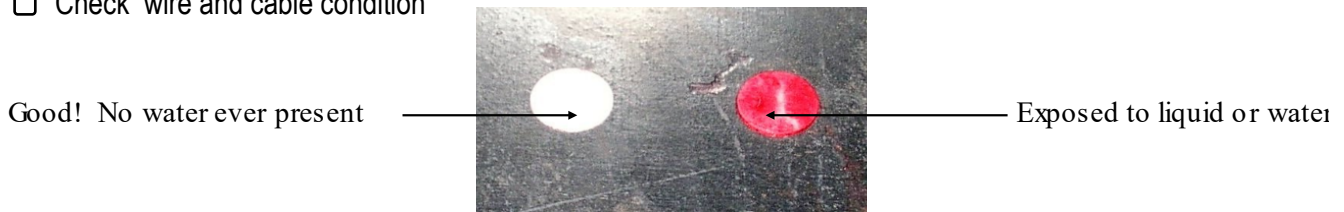

Figure 7

## Calibration:

- Apply power to the system.
- Make sure that Bypass Switch (SW1) is in the UPS position and the cover is screwed secure.
- Close the input breaker CB1 and then the battery breaker CB2. Verify that each of the following items takes place:
  1. The fans will come on.
  2. The Processor will perform several series of checks.
  3. The Processor will continue starting the system and the display's (refer to Figure 8) Inverter LED lights.

**Note:** The Unit is now on the Inverter.

- Record the set values for the system below.

**Input Voltage:**

L to N \_\_\_\_\_ V, or L1 to L2 \_\_\_\_\_ V

**Output Voltage and Current:**

L1 to N \_\_\_\_\_ V, L2 to N \_\_\_\_\_ V

L1 \_\_\_\_\_ A, L2 \_\_\_\_\_ A

**Note:** all recorded voltages should be measure with True RMS meters.

- Close the Output Breakers.
- Record the set values for the system below.

**Input Voltage:**

L to N \_\_\_\_\_ V, or L1 to L2 \_\_\_\_\_ V

**Output Voltage and Current:**

L1 to N \_\_\_\_\_ V, L2 to N \_\_\_\_\_ V

L1 \_\_\_\_\_ A, L2 \_\_\_\_\_ A

**Note:** all recorded voltages should be measure with True RMS meters.

- Secure cabinet doors; your system is back on line.
- Report any abnormalities observed in test in the "Results" section below.

Result:	
Technician:	Date:

#### 4.4.5 Maintaining the Batteries

Please refer to the following when maintaining batteries:

### CAUTION!

BATTERY CIRCUIT BREAKER OPERATES AT THE RATED BATTERY VOLTAGE AT ALL TIMES. TRIPPED BATTERY CIRCUIT BREAKER INDICATES A SERIOUS PROBLEM THAT MAY RESULT IN SERIOUS INJURY OR DAMAGE TO THE EQUIPMENT IF CIRCUIT BREAKER IS CLOSED WITHOUT KNOWING WHY IT FAILED. CHECK FOR SHORTS IN BATTERY OR CALL DSPM CUSTOMER SERVICE AND SUPPORT FOR ASSISTANCE.

### WARNING!

THE BATTERY ELECTROLYTE IS A DILUTED SULFURIC ACID THAT IS HARMFUL TO THE SKIN AND EYES. IT IS ELECTRICALLY CONDUCTIVE AND CORROSIVE. WEAR FULL EYE AND HAND PROTECTION ALONG WITH PROTECTIVE CLOTHING. IF THE ELECTROLYTE CONTACTS THE SKIN, WASH IT OFF IMMEDIATELY WITH WATER. IF ELECTROLYTE CONTACTS THE EYES, FLUSH THOROUGHLY AND IMMEDIATELY WITH WATER. SEEK IMMEDIATE MEDICAL ATTENTION. SPILLED ELECTROLYTE SHOULD BE WASHED DOWN WITH A SUITABLE ACID NEUTRALIZING AGENT. ONE COMMON PRACTICE IS TO USE A SOLUTION OF APPROXIMATELY ONE POUND (500 GRAMS) OF BICARBONATE OF SODA TO APPROXIMATELY ONE GALLON (4 LITERS) OF WATER. THE BICARBONATE OF SODA SOLUTION SHOULD BE APPLIED TO THE SPILL UNTIL EVIDENCE OF CHEMICAL REACTION (FOAMING) HAS CEASED. THE RESULTING LIQUID SHOULD BE FLUSHED WITH WATER AND THE AREA DRIED.

### WARNING!

DO NOT DISPOSE OF A BATTERY OR BATTERIES IN A FIRE. THE BATTERIES MAY EXPLODE CAUSING DEATH OR SERIOUS INJURY.

### WARNING!

LEAD-ACID BATTERIES CONTAIN HAZARDOUS MATERIALS. BATTERIES MUST BE HANDLED, TRANSPORTED, AND RECYCLED OR DISCARDED IN ACCORDANCE WITH FEDERAL, STATE, AND LOCAL REGULATIONS. BECAUSE LEAD IS A TOXIC SUBSTANCE, LEAD-ACID BATTERIES SHOULD BE RECYCLED RATHER THAN DISCARDED.

DO NOT DISPOSE OF BATTERIES IN A FIRE, THE BATTERIES MAY EXPLODE.

DO NOT OPEN OR MUTILATE THE BATTERIES. RELEASED ELECTROLYTE IS HARMFUL TO THE SKIN AND EYES AND MAY BE TOXIC.

A BATTERY CAN HAVE A HIGH SHORT CIRCUIT CURRENT AND PRESENT A RISK OF ELECTRICAL SHOCK. THE FOLLOWING PRECAUTIONS SHOULD BE OBSERVED WHEN WORKING ON BATTERIES:

1. REMOVE WATCHES, RINGS OR OTHER METAL OBJECTS.
2. BE CAREFUL NOT TO TOUCH OR GROUND YOURSELF OR TOOLS TO ANYTHING WHILE DISCONNECTING OR INSTALLING JUMPERS!

3. USE TOOLS WITH INSULATED HANDLES (FOR A METHOD OF INSULATING YOUR EXISTING TOOLS, REFER TO FIGURE 9).
4. WEAR RUBBER GLOVES AND BOOTS.
5. DO NOT LAY TOOLS OR METAL PARTS ON TOP OF BATTERIES.
6. DISCONNECT CHARGING SOURCE PRIOR TO CONNECTING OR DISCONNECTING BATTERY TERMINALS.
7. DETERMINE IF BATTERY IS INADVERTENTLY GROUNDED. IF SO, REMOVE THE SOURCE OF THE GROUND. CONTACT WITH ANY PART OF A GROUNDED BATTERY CAN RESULT IN ELECTRICAL SHOCK. THE LIKELIHOOD OF SUCH SHOCK WILL BE REDUCED IF SUCH GROUNDS ARE REMOVED DURING INSTALLATION AND MAINTENANCE.
8. LEAD-ACID BATTERIES CAN PRESENT A RISK OF FIRE BECAUSE THEY GENERATE HYDROGEN GAS. THE FOLLOWING PROCEDURES SHOULD BE FOLLOWED:
  - DO NOT SMOKE WHEN NEAR BATTERIES.
  - DO NOT CAUSE FLAME OR SPARK IN BATTERY AREA.
9. DISCHARGE STATIC ELECTRICITY FROM YOUR BODY BEFORE TOUCHING BATTERIES BY FIRST TOUCHING A GROUNDED SURFACE.

 **WARNING!**

MAKE SURE THE PROPER POLARITY IS OBSERVED. DC BUS VOLTAGE FOR A TWENTY (20) BATTERY STRING SHOULD BE BETWEEN 240 AND 272 VDC AS TESTED AT THE TOP OF CB2 (REFER TO FIGURE 12A, B—SYSTEM COMPONENT LAYOUT).

 **WARNING!**

AFTER SERVICING THE BATTERIES, ENSURE THAT EACH STRING (EACH STRING IS 2 BATTERIES TOTAL) CONSIST OF THE NUMBER OF BATTERIES INDICATED BY THE BATTERY LAYOUT AND THE MEASURED VOLTAGE FROM THE FIRST TO THE LAST BATTERY IS WITHIN THE VOLTAGE RANGE STATED ABOVE.

#### 4.4.6. CHARGING OF THE BATTERIES

The Emergency Lighting Inverter System charges its battery whenever it is connected to utility power and the input circuit breakers (CB1) is turned on. Disconnect charging source prior to connecting or disconnecting battery terminals. For the best results, charge the battery for 24 hours after they are hooked up and the ELI is brought on line.



## 5. DISPLAYS

### 5.1 FRONT PANEL DESCRIPTION

#### LCD Displays

Refer to Figure 12 for descriptions of the Front Panel display's buttons and LCD.

5.1.1. –AC Input Voltage(1): System will display AC voltage applied to UPS utility input.

5.1.2. –AC Output Voltage(4): System will display AC voltage provided by UPS to load.

5.1.3. – Battery Voltage(2): System will display DC voltage from battery.

5.1.4. – Load Percentage(5): System will display load capacity in percentage.

5.1.5. – UPS Operation Mode Indicator(3.a):

“REC” LED indicates when system is rectifying AC input

Solid Green light: - Rectifier Normal

Blinking Green Light: - Rectifier Initializing

Solid Red Light: - Rectifier Fault

Blinking Red Light: - Rectifier Alarm

Light OFF: - Rectifier OFF

“BYP” LED indicates when system is operating in bypass mode

Solid Green light: - Load on Bypass

Light OFF: - Load Not on Bypass

“INV” LED indicates when system is operating in inverter mode and conditioning AC output.

Solid Green light: - Load on Inverter Normal

Blinking Green Light: - Inverter Initializing

Solid Red Light: - Load not on Inverter Fault

Blinking Red Light: - Load not on Inverter Alarm

Light OFF: - Inverter OFF

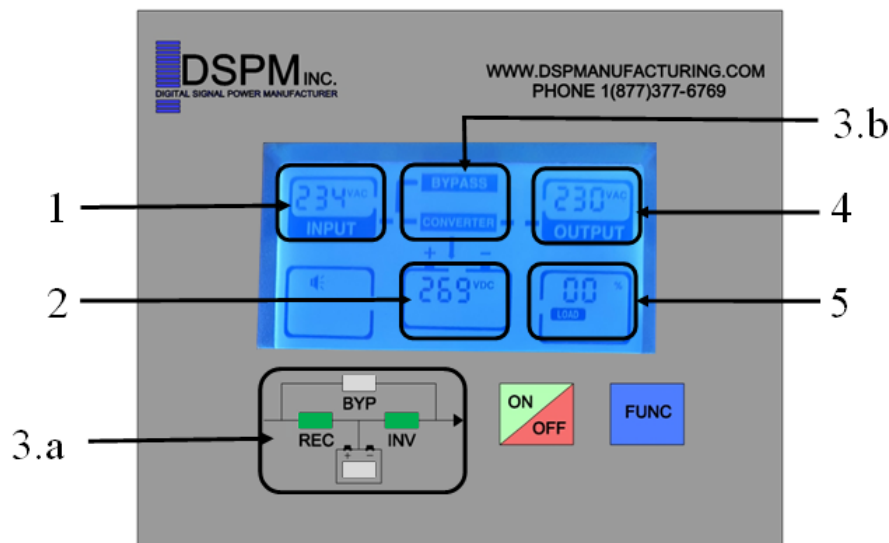

Figure 12

“Battery” LED indicates when system is operating in battery mode.

Solid Green light: - Battery Charging

Blinking Green Light: - Battery Discharging

Solid Red Light: - Battery Fault

Blinking Red Light: - Battery Alarm

Light OFF: - Battery Connected not charging

5.1.5 – UPS Operation Mode (3.b): LCD single line diagram will change depending on current state of operation, Refer to Figure 13.

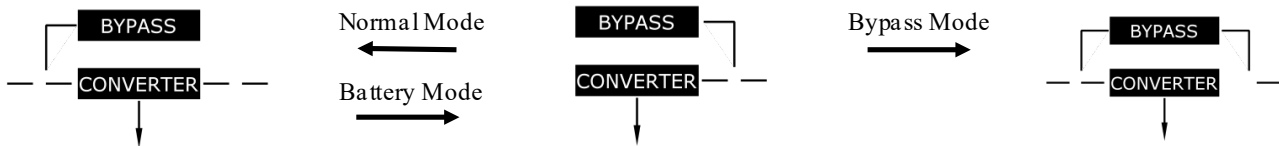

Figure 13

5.1.6.— Other Indicators:

Label (Refer to Figure 14)	Description
Input Information	<b>Main Input:</b> Voltage VAC, Current A, Frequency Hz <b>Bypass Input(When “B” Icon Blinks):</b> Voltage VAC, Current A, Frequency Hz
Battery Information	<b>Battery:</b> Voltage VDC, Discharge/Charge Current A, Remaining Capacity %, Battery Alarm LOW!
Output Information	<b>Main Output:</b> Voltage VAC, Current A, Frequency Hz
Alarm	🔊 : Mute ON/OFF <b>OVER LOAD!:</b> Load is exceeding system rated capacity <b>SHORT:</b> Output is shorted (Over-Current)
Load/Version/Code	<b>Load:</b> Active load kW, Apparent load kVA, Load percentage % <b>VER:</b> Firmware version <b>MODE (System Mode):</b> “S” - Single mode, “P” - Parallel mode
Other	“B”: Bypass input menu “BYPASS”: Operating in Bypass mode

Table 2

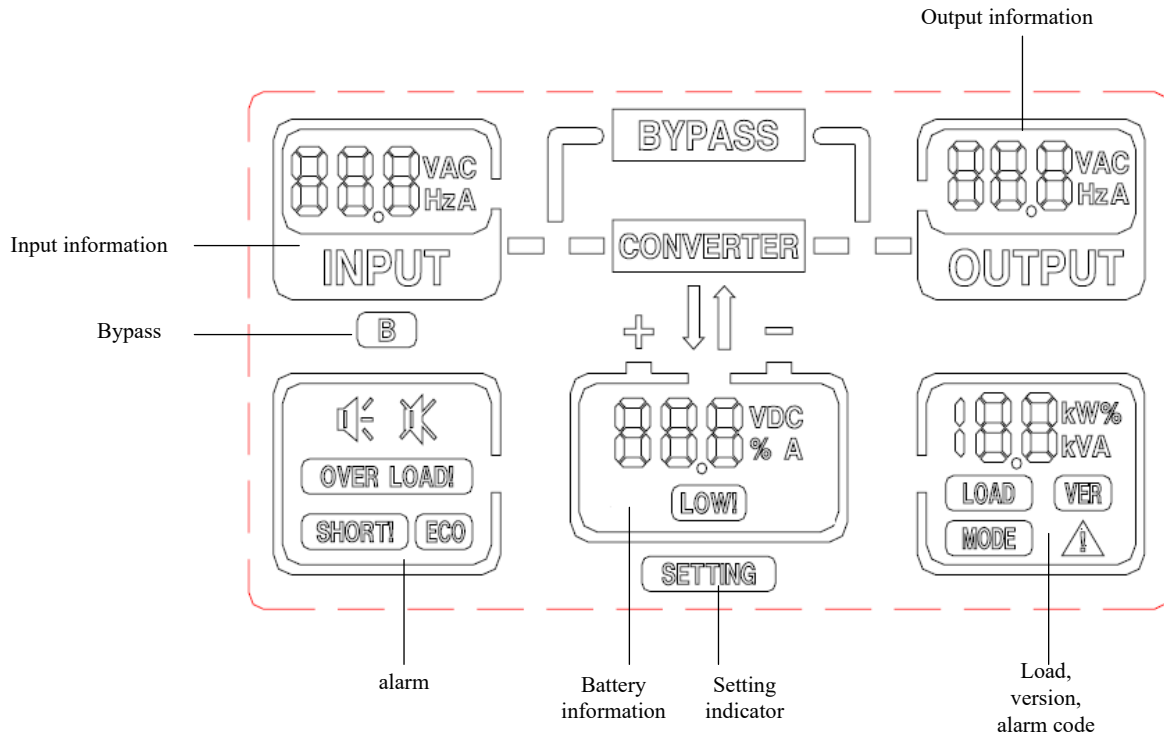

Figure 14

### 5.1.7. – Button Operation:

**“ON/OFF” Key:**

Press this button to turn on or off inverter.

Press this button to shutdown UPS completely when in battery mode.

**“FUNC” Key:**

Press this button to navigate through different menu.

Press and hold this button at main menu for 2.5s to turn on or off mute function.

Press and hold this button at fault menu for 2.5s to clear fault.

## 6. OPERATION AND PROCEDURE

The initial startup must be done by a factory authorized technician or in conjunction with DSPM.



**PLEASE CALL FOR STARTUP BEFORE APPLYING POWER TO THE UPS!**



## 6.1. START-UP PROCEDURE

- 6.1.1. After making all power and grounding connections to the Emergency Lighting Inverter System; verify that all system breakers are set in the OFF position, and the Manual Bypass Switch (MBS) is in the UPS Position.
- 6.1.2. Energize the building feeder circuit for the input power for the UPS.
- 6.1.3. Turn on the DC circuit breaker (CB2). Set the Input Breaker (CB1) to the “ON” position, and verify that each of the following items takes place:
  - 6.1.3.1. The fans come on.
  - 6.1.3.2. The Processor perform a series of checks (These checks will be indicated by the display panels (see CH 7 Figure 12).
- 6.1.4. After the cycling of the LCD screen, the UPS will turn on inverter and energize Output Breaker (CB3).



**With the Batteries properly connected about 20 Second after unit is up and running, the batteries will automatically be placed online to the UPS.**



- 6.1.5. Wait for the Displays to switch to the “Inverter”.
- 6.1.6. Set the OUTPUT BREAKER (CB3) to the ON position.
- 6.1.7. Verify the output voltage is correct BEFORE POWERING the intended load.
- 6.1.8. Power up all electrical equipment connected to the UPS, as specified by the equipment manufacturers.

## 6.2. SHUT-DOWN PROCEDURE

- 6.2.1. Power down all electrical equipment connected to the UPS.
- 6.2.2. Press and hold the “OFF” key until the inverter beeps.
- 6.2.3. Set all OUTPUT BREAKERS to the OFF position.
- 6.2.4. Set the INPUT (CB1) to the OFF position.
- 6.2.5. Set the BATTERY (CB2) to the OFF position.
- 6.2.6. De-energize the input feeder breaker.

## 6.3. BATTERY RUN AUDIBLE ALARM

When the system is running on “Battery Backup” mode, the system will emit an audible alarm. The alarm stops when the Emergency Lighting Inverter System returns to “Normal” mode operation. Pressing the “FUNC” key for 2 seconds can silence the alarm during backup mode. In the backup mode the alarm occurs every 2 minutes until low battery.

## 6.4. LOW BATTERY (RAPID ALARM)

In the “Backup” mode, when the energy of the battery is 5% - 10%, the system beeps rapidly until the system shuts down.



**The “Low Battery” alarm condition cannot be silenced.**



## 7. SYSTEM OPTIONS

### 7.1. UNIT OPTIONS

#### ECM120 and ECM277—Environmental Control Module

Environmental Control Module (ECM) provides superior dependability and security to commercial and industrial environments. It can operate individual fixtures, lamps, circuits, or be daisy chained for controlling multiple loads (One ECM is used per switching device or circuit)/qty. The ECM is perfect for hallways, classrooms, corridors, meeting rooms or individual offices.

The ECM was designed specifically for the egress emergency lighting market. It is a small module that has many applications. The dimensions are 1.25"x1"x2", and comes in two voltage sensing ranges—a 100VAC which has a range of 100-140VAC, and a 200VAC which has a 200-300VAC range. This small and powerful unit is the most versatile module for many applications in the egress emergency lighting market.

The DSPM difference is the patented ECM which is connected to selected fixtures and/or lamps which allows normal operating parameters to be maintained. In the event of an AC power outage, the fixtures, lamps and/or loads connected to the ECM will continue or immediately begin operating at full-light output for a maximum of 90 minutes (or other run time as required by UL924 egress codes).

#### NOF—Normally OFF Circuit 120Vac or 277Vac

Normally OFF Circuit output is an excellent option when the customization needs is to provide, in addition, power only in cases of emergency (i.e. exiting lighting or evacuation power). In the event of an AC power outage, the fixtures, lamps and/or loads connected to the emergency circuit (s) will immediately begin operating at full-light output for a maximum of 90 minutes (or other run time as required by UL924 egress codes).

#### NOH—Normally OFF “Hold On” Circuit 120Vac or 277Vac

Normally OFF “Hold On” Circuit outputs are basically the same as our Normally Off Circuit option. Both are excellent options when the customization needs is to provide, in addition, power only in cases of emergency (i.e. exiting lighting or evacuation power). The difference between the two is that the NOH feature allows the emergency circuit (up to 10 minutes) to remain energized after the utility power is restored. This means that in the event of an AC power outage, the fixtures, lamps and/or loads connected to the emergency circuit (s) will immediately begin operating at full-light output for a maximum of 90 minutes (or other run time as required by UL924 egress codes). When utility power is restored, the emergency circuit (s) will stay energized for up to 10 minutes (depending on user setting). At the end of the preset time, the normally-off circuit (s) will shutoff. OCB—Output Circuit Breaker/(s)

#### EPO—Emergency Power Off

Emergency Power Off option gives the user the ability to instantly turning the UPS off without having to throw the breakers. The EPO option is primarily used as a personnel safety feature that will shutoff all power to the UPS output and load. When pressed the input utility power is still on the terminal block, but the microprocessor turns the inverter and rectifier off.

and load. When pressed the input utility power is still on the terminal block, but the microprocessor turns the inverter and rectifier off.

### RSSP—Remote Indicator Panel

Remote Indicator Panel option enables the user to remotely monitor the UPS. Through the use of relays, the RSSP allows the user to know if the UPS is operating on the input utility power or its battery bank and if the UPS's output is "On" or "Off". This feature allows for the UPS to be located away from the load that it operates or controls.

### SNMP—SNMP Card

Simple Network Management Protocol (SNMP) is an "Internet-standard protocol for managing devices on IP networks." Devices that typically support SNMP include routers, switches, servers, workstations, printers, modem racks, and more. It is used mostly in network Management systems to monitor network-attached devices for conditions that warrant administrative attention.

UPS and Emergency Lighting Inverter manufacturers have adopted the SNMP standard to allow users to easily communicate with their UPS systems. SNMP makes it possible for one node on a network to communicate with another node enabling the power supply to send out emails to anyone on the network, if an email server is available.

DSPM will remain at the cutting edge of technology and convenience by having SNMP as an option on its power supplies. The SNMP will be able to send emails to interested parties when a problem with the power supply occurs. The SNMP will host a java webpage that shows all the relevant voltages, currents, powers, energies, times, alarms, associated with the power supply. The operator will also be able to remotely operate the power supply as if they are standing in front of it pushing buttons.

### FAX—Fax Modem

Facsimile Modulator-Demodulator (Fax Modem) is a "Telephone line managing devices on an IP networks. Its standard features allow users to send a fax by using the telephone access of an E-mail service, and receive incoming and send outgoing faxes via E-mail with the Fax content presented as a file attachment." Devices that typically support FAX include routers, switches, servers, workstations, printers, and more.

A fax modem enables a computer to transmit and receive documents. A fax modem is like a data modem but is designed to transmit and receive documents to and from a fax machine or another fax modem. Some, but not all, fax modems do double duty as data modems.

UPS and Emergency Lighting Inverter manufacturers have adopted the FAX to allow users to easily communicate with their UPS systems via a telephone line. FAX makes it possible for node network communicate with the UPS systems to send out emails to anyone on the network, if an email server is available.

DSPM will remain at the cutting edge of technology and convenience by having FAX as an option on its power supplies. The FAX will be able to send emails to interested parties when a problem with the power supply occurs.

## MB—Modbus Interface

Modbus Interface is a serial communications protocol that is simple and robust for connecting industrial electronic devices. Modbus is often used to connect a supervisory computer with a remote terminal unit (RTU) in supervisory control and data acquisition systems. Modbus allows for communication between a system that measures temperature, real power, load percentile, battery current, and frequency, and communicates the measured results to a computer.

DSPM will remain at the cutting edge of technology and convenience by having MB as an option on its power supplies. Our lighting inverter are programmed to “talk Modbus”. DSPM’s lighting inverters respond to commands send through TCP Modbus. We use a gateway that converts the Ethernet physical layer into a RS232 physical layer which our control board uses. With the use of MB, the user will be able to monitor normal operation and know when problems occurs with the UPS or its load (s).

## FC—Form C Contacts

Form C Contacts is an option to be used when it is necessary to turn on or off one device by another device. This is done by the Form C Contacts control of two circuits: one normally-open contact and one normally-closed contact with a common terminal. One use of Form C Contacts may be with an automatic dialer. If the output of the UPS goes off, the automatic dialer hooked to the normally “Off” contacts will energize calling the maintenance telephone.

## SRB—Seismic-Rated Bracket

DSPM’s Seismic-Rated Brackets are built for use in seismic zone 0 through 4. DSPM’s Seismic-Rated Brackets are Ideal for blocking and strapping to foundation to hold UPSs in place in case of earthquake. Consult your local building code or official for information about local zoning laws.

## STU3—Onsite Startup

Onsite Startup is an option that can be purchased along with all DSPM’s product when the standard Telephone Startup is not what you desire. When purchased, we send a qualified technician to your site to do the startup.

## EW—Extended Warranty

Extended Warranty is for one (1) year onsite parts and labor.

## OCB—Output Circuit Breaker/(s) 120Vac or 277Vac

Output Circuit Breaker/(s) are an excellent feature for separating and controlling the load in the UPS. Furthermore, the controlling of the individual branches that constitutes your load can be done while the UPS is running, giving the customer multiple options or ways to use their UPSs.

## 7.2. SERVICE PROGRAM DESCRIPTIONS

### TOS Equipment Turn On Service WITHOUT On Site Warranty

- \* Equipment Turn On Service is for customer that would like to have start-up performed without adding additional coverage to the of the equipment warranty.
- \* This coverage can be performed as an On-Site Startup Service for any DSPM product.
- \* All parts and labor to repair if **NOT** covered under a current Warranty or Service Plan and will be billed from DSPM current rates unless covered by a current warranty or service plan.

### CI Certification Inspection Visit

- \* The Certification/Inspection is a service provided to certify equipment capable is placed under a warranty/service plan.
- \* The Certification Inspection is complete when all repairs are completed
- \* The Certification Inspection is billed at DSPM current hourly rates based on time of day and day of week service is performed.
- \* All part needed to complete the repairs are billed from DSPM current list prices.

### SW58 Extended On-Site Warranty 8-5 Mon.-Fri.

- \* This Extended Warranty Plan is to be purchased while the equipment is still under current warranty coverage, or after approval by DSPM and a Certification Inspection by DSPM.
- \* This plan covers all replacement parts and labor including travel time and expenses for all emergency calls to service the unit. All service calls will be made between 8:00 a.m. and 5:00 p.m. and will be limited to Monday through Friday with the exception of the DSPM's designated holidays.
- \* If the Customer requests remedial maintenance outside of the contracted coverage or preventive maintenance, DSPM will provide this service. This service will be charged to the Customer at DSPM's standard hourly rates in effect at the time of the service, and will be subject to an available field engineer.
- \* DSPM will provide all replacement parts for parts that are found defective during emergency service calls. If replaced parts are used from any Customer- spare parts kit, DSPM will replace them to the Customer-owned spare parts kit with no charges to the Customer.
- \* DSPM will include installation of any changes for safety reasons and at DSPM option, install any factory enhancements and upgrades, and reliability changes or improvements during the emergency service call. Uninterruptible Power Systems (UPS) and Emergency Lighting Inverter's batteries are **NOT** warranted under this plan unless specified. DSPM will provide the maintenance and testing for the batteries at DSPM's the hourly rates in effect for DSPM. DSPM unless specified otherwise in contract, will **NOT** provide Battery replacements but will assist the customer in the replacement of the batteries through the battery manufacturers warranty.



## SW724 Extended On-Site Warranty 24Hr/day 7Days/week Except Holidays

- \* This Extended Warranty Plan is to be purchased while the equipment is still under current warranty coverage, or after approval by DSPM and a Certification Inspection by DSPM.
- \* This plan covers all replacement parts and labor including travel time and expenses for all emergency calls to service the unit. All service calls will be made Seven (7) days a week exception of the DSPM's designated holidays.
- \* If the Customer requests remedial maintenance outside of the contracted coverage or preventive maintenance, DSPM will provide this service. This service will be charged to the Customer at DSPM's standard hourly rates in effect at the time of the service, and will be subject to an available field engineer.
- \* DSPM will provide all replacement parts for parts that are found defective during emergency service calls. If Replaced parts are used from any Customer-spare parts kit, DSPM will replace them to the Customer-owned spare parts kit with no charges to the Customer.
- \* DSPM will include installation of any changes for safety reasons and at DSPM option, install any factory enhancements and upgrades, and reliability changes or improvements during the emergency service call. Uninterruptible Power Systems (UPS) and Emergency Lighting Inverter's batteries are **NOT** warranted under this plan unless specified. DSPM will provide the maintenance and testing for the batteries at DSPM's the hourly rates in effect for DSPM. DSPM unless specified otherwise, will **NOT** provide Battery replacements but will assist the customer in the replacement of the batteries through the battery manufacturers warranty.

## SW36 Extended On-Site Warranty 24Hr/day 7Days/week including Holidays

- \* This Extended Warranty Plan is to be purchased while the equipment is still under current warranty coverage, or after approval by DSPM and a Certification Inspection by DSPM.
- \* This plan covers all replacement parts and labor including travel time and expenses for all emergency calls to service the unit. All service calls will be made Seven (7) days a week exception of the DSPM's designated holidays.
- \* If the Customer requests remedial maintenance outside of the contracted coverage or preventive maintenance, DSPM will provide this service. This service will be charged to the Customer at DSPM's standard hourly rates in effect at the time of the service, and will be subject to an available field engineer.
- \* DSPM will provide all replacement parts for parts that are found defective during emergency service calls. If Replaced parts are used from any Customer- spare parts kit, DSPM will replace them to the Customer-owned spare parts kit with no charges to the Customer.
- \* DSPM will include installation of any changes for safety reasons and at DSPM option, install any factory enhancements and upgrades, and reliability changes or improvements during the emergency service call. Uninterruptible Power Systems (UPS) and Emergency Lighting Inverter's batteries are **NOT** warranted under this plan unless specified. DSPM will provide the maintenance and testing for the batteries at DSPM's the hourly rates in effect for DSPM. DSPM unless specified otherwise, will **NOT** provide Battery replacements but will assist the customer in the replacement of the batteries through the battery manufacturers warranty.

### SF58-n Full Service Contract 8-5 Mon.-Fri.

- \* This Full Service Plan is to be purchased while the equipment is still under current warranty coverage, or after approval by DSPM and a Certification Inspection by DSPM.
- \* This Full Service Plan covers all emergency calls to service the unit and one (1) Preventive Maintenance call per year. Additional Preventive Maintenance calls can per purchased/added to the plan.
- \* This plan covers all replacement parts and labor including travel time and expenses for all emergency calls and one (1) Preventive maintenance call to service the unit. All service calls will be made between 8:00a.m. and 5:00p.m.
- \* If the Customer requests remedial maintenance or preventive maintenance outside of the contracted coverage, DSPM will provide this service. This service will be charged to the Customer at DSPM's standard hourly rates in effect at the time of the service, and will be subject to an available field engineer.
- \* DSPM will provide all replacement parts for parts that are found defective during emergency service calls. If Replaced parts are used from any Customer- spare parts kit, DSPM will replace them to the Customer-owned spare parts kit with no charges to the Customer.
- \* DSPM will include installation of any changes for safety reasons and at DSPM option, install any factory enhancements and upgrades, and reliability changes or improvements during the preventive maintenance service call. Uninterruptible Power Systems (UPS) and Emergency Lighting Inverter's batteries are **NOT** warranted under this plan unless specified. DSPM will provide the maintenance and testing for the batteries at DSPM's the hourly rates in effect for DSPM. DSPM unless specified otherwise, will **NOT** provide Battery replacements but will assist the customer in the replacement of the batteries through the battery manufacturers warranty.

### SF724-n Full Service Contract 24Hr/day 7 Days/week Except Holidays

- \* This Full Service Plan is to be purchased while the equipment is still under current warranty coverage, or after approval by DSPM and a Certification Inspection by DSPM.
- \* This Full Service Plan covers all emergency calls to service the unit and one (1) Preventive Maintenance call per year. Additional Preventive Maintenance calls can per purchased/added to the plan
- \* This plan covers all replacement parts and labor including travel time and expenses for all emergency calls and one (1) Preventive maintenance call to service the unit. All service calls will be made Seven (7) days a week with exception of the DSPM's designated holidays.
- \* If the Customer requests remedial maintenance or preventive maintenance outside of the contracted coverage, DSPM will provide this service. This service will be charged to the Customer at DSPM's standard hourly rates in effect at the time of the service, and will be subject to an available field engineer.
- \* DSPM will provide all replacement parts for parts that are found defective during emergency service calls. If Replaced parts are used from any Customer- spare parts kit, DSPM will replace them to the Customer-owned spare parts kit with no charges to the Customer.
- \* DSPM will include installation of any changes for safety reasons and at DSPM option, install any factory enhancements and upgrades, and reliability changes or improvements during the preventive maintenance service call. Uninterruptible Power Systems (UPS) and Emergency Lighting Inverter's batteries are **NOT** warranted under this plan unless specified.

DSPM will provide the maintenance and testing for the batteries at DSPM's the hourly rates in effect for DSPM. DSPM unless specified otherwise, will NOT provide Battery replacements but will assist the customer in the replacement of the batteries through the battery manufacturers warranty.

### **SF365-n Full Service Contract 24Hr/day 7 Days/week including**

- \* This Full Service Plan is to be purchased while the equipment is still under current warranty coverage, or after approval by DSPM and a Certification Inspection by DSPM.
- \* This Full Service Plan covers all emergency calls to service the unit and one (1) Preventive Maintenance call per year. Additional Preventive Maintenance calls can per purchased/added to the plan
- \* This plan covers all replacement parts and labor including travel time and expenses for all emergency calls and one (1) Preventive maintenance call to service the unit. All service calls will be made Seven (7) days a week with exception of the DSPM's designated holidays.
- \* If the Customer requests remedial maintenance or preventive maintenance outside of the contracted coverage, DSPM will provide this service. This service will be charged to the Customer at DSPM's standard hourly rates in effect at the time of the service, and will be subject to an available field engineer.
- \* DSPM will provide all replacement parts for parts that are found defective during emergency service calls. If Replaced parts are used from any Customer-spare parts kit, DSPM will replace them to the Customer-owned spare parts kit with no charges to the Customer.
- \* DSPM will include installation of any changes for safety reasons and at DSPM option, install any factory enhancements and upgrades, and reliability changes or improvements during the preventive maintenance service call. Uninterruptible Power Systems (UPS) and Emergency Lighting Inverter's batteries are NOT warranted under this plan unless specified. DSPM will provide the maintenance and testing for the batteries at DSPM's the hourly rates in effect for DSPM. DSPM unless specified otherwise, will NOT provide Battery replacements but will assist the customer in the replacement of the batteries through the battery manufacturers warranty.

Plan Type	COVERAGE	LABOR	PARTS	TRAVEL EXPENSES	EMERGENCY CALLS	PREVENTIVE MAINTENANCE
TOS	8-5 Mon-Fri	X	X <sup>1</sup>	X		
CI	Service is as per customer request	X		X		
SW58*	8-5 Mon-Fri	X	X	X	X	
SW724*	7 days per week 24 hours per day Except Holidays	X	X	X	X	
SW365*	7 days per week 24 hours per day Including Holidays	X	X	X	X	
SF58-n*	8-5 Mon-Fri	X	X	X	X	X
SF724-n*	7 days per week 24 hours per day Except Holidays	X	X	X	X	X
SF365-n*	7 days per week 24 hours per day Including Holidays	X	X	X	X	X

Table 3

X Included with Plan Type

X1 Included If Performed During Warranty Period or With Unit Under a Service Contract. Coverage for parts must be from other coverage such as an Extended Warranty or Service Contract.

-n indicates the number of Preventive Maintenance Calls per year

\* Must be purchased during an active original factory warranty, during an active Extended Warranty, during an active Service Contract, or After a CI with DSPM Management approval.

Multiple Unit discount for more then one unit at a single location only, and startups are all at the same time.

### SERVICE AND SUPPORT AT ALL TIMES

## 8. APPENDIX

### 8.1. FIGURES AND TABLES

<b>Troubleshooting</b>		
If UPS alarms and buzzer sound, press "FUNC" key to get alarm code on the fault menu. To clear fault press and hold "FUNC" key for 2.5s at fault menu		
<b>Code</b>	<b>Cause</b>	<b>Solutions</b>
7	No Battery	<ul style="list-style-type: none"> <li>•Check if battery cables are connected properly</li> <li>•Check if battery breaker or fused are open</li> <li>•Check if batteries are damaged</li> </ul>
8	Manual Bypass ON	Manual bypass housing open, UPS will transfer will transfer to static bypass and will impede inverter operation mode.
10	EPO	<ul style="list-style-type: none"> <li>•Check if EPO is closed correctly</li> <li>•Check if EPO is activated manually</li> </ul>
16	Utility Abnormal	<p>UPS mains input is abnormal.</p> <ul style="list-style-type: none"> <li>•Check if mains input is normal</li> <li>•Check if mains input voltage and frequency is over the working range</li> <li>•Check if mains input breaker or external input breaker is opened</li> </ul> <p>Please recover mains input power, otherwise output will be shutdown if battery is discharged to EOD.</p>
20	Bypass Abnormal	<p>Check if bypass input power is abnormal</p> <p>Check if bypass input breaker is opened</p>
22	Bypass Faulty	Bypass SCR is opened or shorted, please contact DSPM.
24	Bypass Overload	•Check the load and remove some non critical load until the load is below 95%
26	Bypass Overload Timeout	Bypass overload and timeout, UPS will shutdown output.
28	Over Synchronization	Bypass voltage or frequency is over tracking range. There could be interruption if manually transferred to bypass or inverter faults.
30	Over Transfer Times	Main, battery, inverter, or bypass transfer occur 5 times in 1 Hour.
32	Output Shorted	<p>Load is abnormal or output breaker is shorted.</p> <ul style="list-style-type: none"> <li>• Check load for short and eliminate if any</li> <li>• Check output breaker for short</li> </ul> <p>After verifying no short is present at output, restart UPS.</p>
47	Rectifier Fault	DC BUS over/under voltage, or shorted/opened IGBT. Restart UPS, if issue still persist contact DSPM.
49	Inverter Fault	Inverter voltage is abnormal, or inverter IGBT is shorted/opened. Restart UPS, if issue still persist contact DSPM.
51	Rectifier Over Temperature	<p>Rectifier heatsink is reading above maximum threshold.</p> <ul style="list-style-type: none"> <li>• Check if fans are working properly</li> <li>• Check if anything blocking ventilation</li> <li>• Check if the temperature sensor is connected correctly</li> <li>• Check if the environmental temp is over the range of UPS</li> </ul>

Table 4

<b>Troubleshooting Cont.</b>		
If UPS alarms and buzzer sound, press "FUNC" key to get alarm code on the fault menu. To clear fault press and hold "FUNC" key for 2.5s at fault menu		
<b>Code</b>	<b>Cause</b>	<b>Solutions</b>
53	Fan Fault	One or more fans are not working properly or failed. <ul style="list-style-type: none"> <li>• Check if fans all fans are working normally</li> <li>• Check if something is blocking fan</li> </ul>
55	Overload	Inverter is operating at higher than rated power. System may transfer to Bypass. <ul style="list-style-type: none"> <li>• Remove non-critical loads until overall loads drops to UPS rated power</li> </ul>
57	Overload Timeout	UPS will transfer to bypass, if overload persist in bypass UPS will shut-down. <ul style="list-style-type: none"> <li>• Remove non-critical load</li> </ul>
59	Inverter Over Temperature	Inverter heatsink is reading above maximum threshold. <ul style="list-style-type: none"> <li>• Check if fans are working properly</li> <li>• Check if anything blocking ventilation</li> <li>• Check if the temperature sensor is connected correctly</li> <li>• Check if the environmental temp is over the range of UPS</li> </ul>
63	Manual Bypass Transfer	If bypass is over synchronization range, output could be interrupted.
65	Battery Low	Battery capacity has reached low limit.
67	Battery Reversed	<ul style="list-style-type: none"> <li>• Check if battery conductors are connected properly</li> </ul>
69	Inverter Protect	Inverter voltage abnormal or DC BUS is over voltage. UPS will clear fault automatically, If not, contact DSPM.
78	Parallel Cable Error	<ul style="list-style-type: none"> <li>• Check if parallel communication cables are connected correctly</li> </ul>
81	Charger Fail	<ul style="list-style-type: none"> <li>• Charger is faulty or is not connected. Contact DSPM.</li> </ul>
119	Relay Open	<ul style="list-style-type: none"> <li>• Inverter relay opened. Contact DSPM.</li> </ul>
121	Relay Closed	<ul style="list-style-type: none"> <li>• Inverter relay closed. Contact DSPM.</li> </ul>

Table 4 Cont.

When insulated grip tools are not available, a method for insulating grips on tools that we use at DSPM using Plasti Dip by Performix is illustrated in Figures 15. The illustration is only an example of how to insulate your tools, i.e. you may want to insulate the open end of the wrench. The product give the user a lot of flexibility when it comes to how many coats to apply (as many as you want). Applying multiple coats by following the instructions on the can should insulate sufficiently.



Figures 15



**DSPM cannot control use of this product and will not accept liability.**



## System Component Layout

The following layout will help you find the parts and components in your Emergency Lighting Inverter. Do not attempt to service. If you need technical assistance, please contact DSPM.

**Maintenance should only be performed by factory-trained or qualified personnel.**

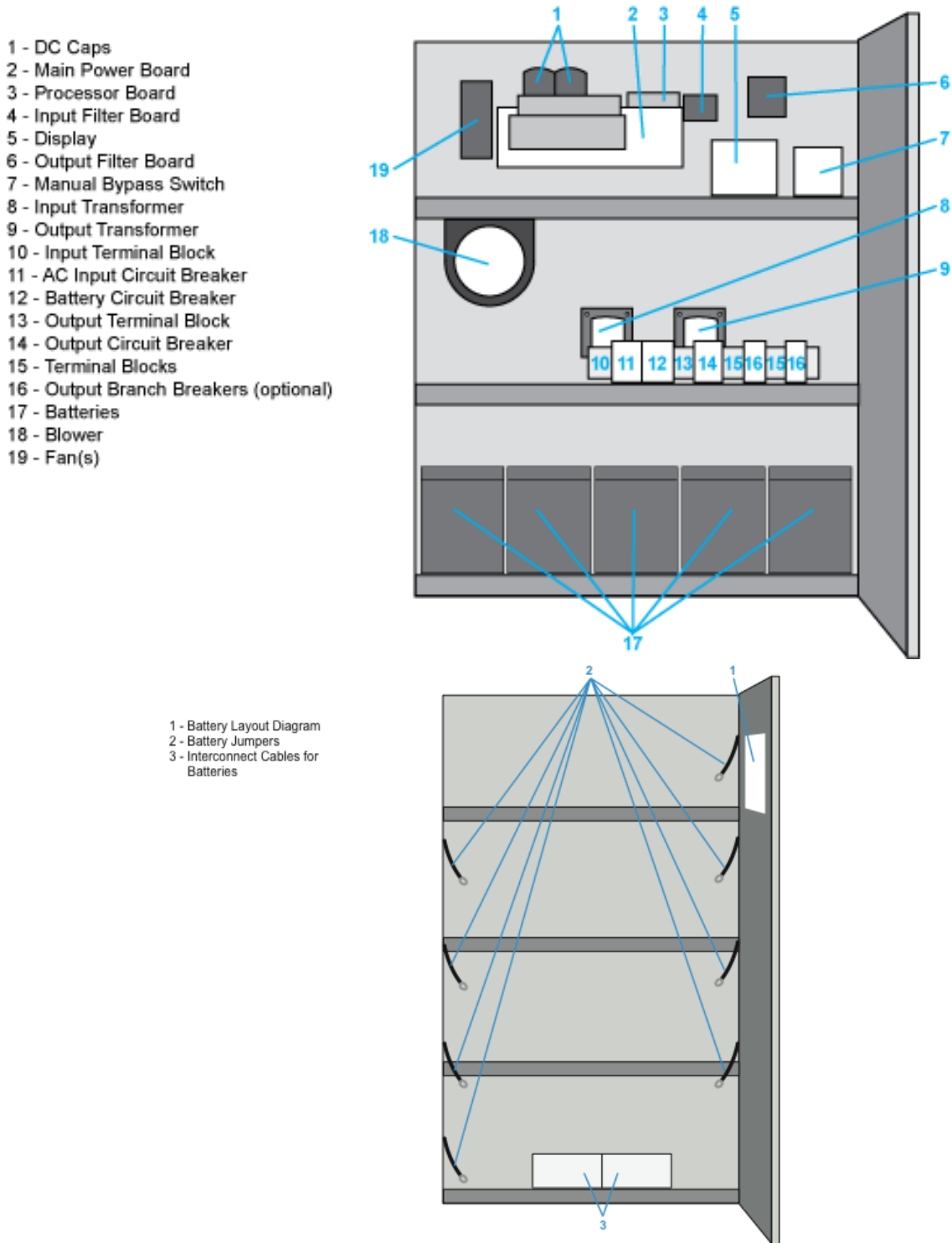

Figure 16



## 8.2. LIMITED WARRANTY

### TEN (10) YEAR DESIGN LIFE VALVE REGULATED LEAD ACID (VRLA) BATTERIES & BATTERY CABINET PRODUCTS

This Warranty is given ONLY to purchasers who buy for commercial or industrial use in the ordinary course of each purchaser's business.

#### General:

DSPM Corporation products and systems are in our opinion the finest available. We take pride in our products and are pleased that you have chosen them. Under certain circumstances we offer with our products the following Warranty Against Defects in Material and Workmanship.

Please read your Warranty carefully. This Warranty sets forth our responsibilities in the unlikely event of defect and tells you how to obtain performance under this Warranty.

### LIMITED WARRANTY

#### AGAINST DEFECTS IN MATERIAL AND WORKMANSHIP PRODUCTS COVERED:

Ten(10) Year Design Life Valve Regulated Lead (VDRLA) Batteries, and DSPM manufactured battery cabinets, for Uninterruptible Power Supply (UPS) system applications.

#### Terms of Warranty:

DSPM-Manufactured Battery Cabinets (not including batteries): As provided herein, each DSPM manufactured battery cabinet is warranted to be free of defects in material and workmanship for a period of: (i) one year from the start-up date provided start-up is performed by DSPM personnel, occurs within six (6) months of the DSPM shipping date and the product has been stored in a suitable environment prior to start-up; or (ii) in any event, a maximum of eighteen (18) months from date of product shipment from DSPM. The warranty duration shall be whichever period described in the preceding sentence expires first. The start-up date will be determined only from the completed inspection and start-up sheet provided DSPM to User. The product shipment date will be determined only from the DSPM bill of lading. If any part or portion of the DSPM product fails to conform to the Warranty within the Warranty period, DSPM, at its option, will furnish new or factory remanufactured products for repair or replacement of that portion or part and reinstall the replacement product.

#### Ten (10) Year Design Life VRLA Batteries:

DSPM does not manufacture batteries, but does warrant certain ten (10) year design life VRLA batteries. Subject to the further conditions and limitations set forth in this document, ten (10) year design life VRLA batteries (the "Warranty VRLA Batteries") that are purchased from DSPM and used in DSPM-manufactured battery cabinets are warranted to be free of defects in material and workmanship for a period of: (i) one year from date of shipment on a full replacement basis with a functionally equivalent battery; and (ii) after the 1st year, an additional nine years on a pro rata basis. The product shipment date will be determined only from the DSPM bill of lading.

From time-to-time DSPM is requested by Users, as defined below, to procure non-Warranty VRLA Batteries for User on a per-order basis.

Under these circumstances, DSPM assigns to User any warranties which are made by the manufacturers and suppliers of such non-VRLA Warranty Batteries and which are assignable, but DSPM makes NO REPRESENTATIONS as to the effectiveness or extent of such warranties, assumes NO RESPONSIBILITY for any matters that may be warranted by such manufacturers or suppliers and extends no coverage under this Warranty to such non-VRLA Warranty Batteries. matters that may be warranted by such manufacturers or suppliers and extends no coverage under this Warranty to such non-VRLA Warranty Batteries.

[Drawings, Descriptions:](#)

DSPM warrants for the period and on the terms of the Warranty set forth herein that the covered product will conform to the descriptions contained in the certified drawings, if any, applicable thereto, to DSPM final invoices, and to applicable DSPM product brochures and manuals published as of the date of product shipment (“Descriptions”). DSPM does not control the use of any product. Accordingly, it is understood that the Descriptions are NOT WARRANTIES OF PERFORMANCE AND NOT WARRANTIES OF FITNESS FOR A PARTICULAR PURPOSE.

[Warranty Claims Procedure:](#)

Within a reasonable time, but in no case to exceed thirty (30) days, after User’s discovery of a defect, User shall contact DSPM at 1-(909) 930-3353. All defective products an component parts replaced under this warranty become the property of DSPM.

[DSPM-Manufactured Battery Cabinet:](#)

Subject to the terms and conditions specified herein, should DSPM determine that the battery cabinet is defective, a DSPM field service representative will repair or replace (at DSPM’S option) the non-conforming DSPM product warranted hereunder, without charge for material or labor, provided start-up of the DSPM product was performed by DSPM personnel. In all other instances, User will be charged for labor performed at DSPM then current rates. Warranty coverage will be extended only after DSPM inspection discloses the claimed defect and shows no signs of treatment or use that would void the coverage of this Warranty.

<b>Pro-Rated Battery Chart</b>	
<b>Years</b>	<b>Percentage</b>
1	100
2	66
3	44
4	29
5	19
6	15
7	8
8	5
9	3
10	2

[Warranty Extends to First Purchaser for Use, Non-transferable:](#)

This Warranty is extended to the first person, firm, association, or corporation for whom the DSPM product specified herein is originally installed for use in the United States or Canada (the “User”). This Warranty is not transferable or assignable without the prior written permission of DSPM.

Ten (10) Year Design Life VRLA Batteries:

Subject to the terms and conditions specified herein, should DSPM determine that a Warranty VRLA Battery is defective within the initial one year warranty period, DSPM will replace the Warranty VRLA Battery with a functionally equivalent battery. During the pro rata portion of the warranty period, DSPM will replace a Warranty VRLA Battery that DSPM determines to be defective based on the below pro rata formula. The formula yields a pro rata credit value, which shall be applied against the battery manufacturer's current published list purchase price of a new product of equal or greater Ampere Hour capacity.

Non-Warranty VRLA Batteries:

With respect to non-Warranty VRLA Batteries procured by DSPM for Users, DSPM makes NO REPRESENTATIONS as to the effectiveness or extent of warranties that may be assigned to Users for such non-Warranty VRLA Batteries. DSPM assumes NO RESPONSIBILITY for any matters that may be warranted by manufacturers or suppliers of non-Warranty VRLA Batteries and extends no coverage under this Warranty to such non-Warranty VRLA Batteries.

PRO RATA CALCULATION FOR CREDIT

$$\frac{[(\text{Reseller's List Purchase Price for the Warranty VRLA Battery}) \times ((\# \text{ of Months of Total Warranty}) - (\# \text{ of Months of Un-Expired Warranty}))] / (\# \text{ of Months of Total Warranty})}{\text{Pro Rata Price}}$$

Warranty Performance of Component Manufacturers:

Warranty Performance of Component Manufacturers:

It is DSPM'S practice, consistent with its desire remedy Warranty defects in the most prompt and effective manner possible, to cooperate with and utilize the services of component manufacturers and their authorized representatives in the performance of work to correct defects in the DSPM components. Accordingly, DSPM may utilize third parties in the performance of Warranty work including repair or replacement hereunder, where, in DSPM'S opinion, such work can be performed in less time, with less expense and in closer proximity to the DSPM product.

Items Not Covered By Warranty:

THIS WARRANTY DOES NOT COVER DAMAGE OR DEFECT CAUSED BY misuse, improper application, wrong or inadequate electrical current or connection, inadequate water or drain services, negligence, inappropriate on site operating conditions, repair by non-DSPM designated personnel, accident in transit, tampering, alterations, a change in location or operating use, exposure to the elements, Acts of God, theft or installation contrary to DSPM'S recommendations or specifications, or in any event if the DSPM (for cabinets) or other manufacturer's (for batteries) serial number has been altered, defaced, or removed.

THIS WARRANTY DOES NOT COVER shipping costs, installation costs, circuit breaker resetting or maintenance or service items and further, except as may be provided herein, does NOT include labor costs or transportation charges arising from the re placement of the product any part thereof or charges to remove same from any premises of User.

THIS WARRANTY IS VOID if User allows any battery for the DSPM UPS product to discharge below the Fortress 1mum battery voltage cutoff point. Furthermore, the warranty is void if the user does not start recharging a discharged battery within forty-eight hours.

REPAIR OR REPLACEMENT OF A DEFECTIVE PRODUCT OR PART THEREOF DOES NOT EXTEND THE ORIGINAL WARRANTY PERIOD.

THE PRODUCTS LISTED IN THIS WARRANTY ARE NOT FOR USE IN THE CONTROL AREA OR ANY REACTOR CONNECTED OR SAFETY APPLICATIONS OR WITHIN THE CONTAINMENT AREA OF A NUCLEAR FACILITY OR WHERE THE PRODUCTS HAVE POTENTIAL FOR DIRECT PATIENT CONTACT OR WHERE A SIX (6) FOOT CLEARANCE FROM A PATIENT CANNOT BE MAINTAINED AT ALL TIMES. THE PRODUCTS LISTED IN THIS WARRANTY MAY BE USED IN APPLICATIONS INVOLVING LIFE-SUSTAINING OR LIFE-SUPPORTING DEVICES ONLY WHERE THE END-USED CUSTOMER HAS SIGNED DSPM'S HEALTHCARE APPLICATION SALES AGREEMENT, OTHERWISE THE WARRANTY IS VOID.

THIS WARRANTY IS IN LIEU OF AND EXCLUDES ALL OTHER WARRANTIES, EXPRESS OR IMPLIED, INCLUDING MERCHANTABILITY AND FITNESS FOR A PARTICULAR PURPOSE.  
USER'S SOLE AND EXCLUSIVE REMEDY IS REPAIR OR REPLACEMENT OF THE PRODUCT AS SET FORTH HEREIN.

